

CERTS Microgrid Demonstration With Large-Scale Energy Storage and Renewable Generation

Eduardo Alegria, *Member, IEEE*, Tim Brown, *Member, IEEE*, Erin Minear, *Member, IEEE*, and Robert H. Lasseter, *Fellow, IEEE*

Abstract—The Consortium for Electric Reliability Technology Solutions (CERTS) Microgrid concept captures the emerging potential of Distributed Energy Resource (DER) using an automatic plug-and-play approach. CERTS views generation and associated loads as a subsystem or a “Microgrid.” The sources can operate in parallel to the grid or can operate in island, providing high levels of electrical reliability. The system can disconnect from the utility during large events (i.e., faults, voltage collapses), but also may disconnect intentionally when the quality of power from the grid falls below certain standards. CERTS Microgrid concepts have been demonstrated at the Alameda County Santa Rita Jail in California. The existing system included a 1-MW fuel cell, 1.2 MW of solar photovoltaic, and two 1.2-MW diesel generators. Adding a 2-MW, 4-MWh storage system, a fast static switch, and a power factor correcting capacitor bank enabled microgrid operation. The islanding and resynchronization methods met all Institute of Electrical and Electronics Engineers Standard 1547 and the reliability requirements of the jail.

Index Terms—Advanced energy storage, distributed generation, distributed resource, islanding, microgrid, renewable energy, smart grid.

I. INTRODUCTION

THE Alameda County Santa Rita Jail Microgrid project is a demonstration of Consortium for Electric Reliability Technology Solutions (CERTS) Microgrid concepts, [1]–[3]. The goal from a research and design perspective is to understand the potential for large commercialization of CERTS Microgrids in the future for customers with demand for reliable power. The CERTS Microgrid concept has been developed over the last 10 years with support from the California Energy Commission and the US Department of Energy. CERTS basic research focus is the design and application of automatic controls for the full range of DER component. The CERTS approach provides standard automatic controls that enable plug-and-play functionality without the need of communication or custom engineering for each application. These features minimize engineering cost

and errors and maximize flexibility. Most microgrid implementations combine loads with sources and allow for intentional landing, but rely on complex communication and control and require custom design including extensive site engineering.

CERTS concepts demonstrated to date at American Electric Power’s microgrid test bed include autonomous load following, local islanding and re-synchronizing with the grid, voltage and frequency control, reduction of circulating reactive power and stable operation for microgrids with multiple DER units. These tests were done without storage or communication between units, [4]–[7]. This functionality is achieved using two droop controllers. One is a power vs. frequency droop much like the traditional droop control on generators. Protection from self-overloading drives the frequency down when the unit becomes overloaded. This results in the other sources off-loading the overloaded unit. The second droop controller is a voltage vs. reactive power controller. When there are voltage error between two or more units there can be large circulating VARS. The reactive power output provided by each source is used modifies its own voltage regulation point. This corrects for the voltage errors and minimize the circulating VARS. Alameda County Santa Rita Jail project provides a platform to extend these concepts to storage, diesel generation and energy management systems.

This project integrates existing 1.2 MW solar photovoltaic, 1 MW fuel cell and conventional diesel generators with large-scale energy storage, a static disconnect switch and a capacitor bank. The project also upgraded the controls of the generators to make them CERTS-capable. An overarching control system referred to as Energy Management System (EMS) to economically optimize was added the use of all generation sources. Refer to Appendix A for a summary of equipment details, Fig. 1.

II. DESIGN CONSIDERATIONS

Prior to the Microgrid project, the Santa Rita Jail facility was susceptible to momentary utility outages and power quality events. Maintaining power free of momentary or sustained outages is critical to the safety of the officers, staff and inmates. To prevent sustained outages, diesel generators were available to power essential facility loads. However, the diesel generators relied on a load-shed system and required approximately 10 seconds to start, during which the facility had no power.

Additionally, the solar photovoltaic and fuel cell generators were unable to operate in parallel with the diesel generators. This was due to a couple of reasons. One, it is challenging for the system to maintain proper microgrid system voltage and frequency within operational limits during transitions to the back-up diesel generators. Additionally, the diesel generator

Manuscript received January 07, 2013; revised May 29, 2013; accepted October 14, 2013. Date of publication November 19, 2013; date of current version February 14, 2014. Paper no. TSG-00010-2013. The work is coordinated by Chevron Energy Solutions and funded by the U.S. Department of Energy and the California Energy Commission Public Interest Energy Research Program.

E. Alegria, T. Brown, and E. Minear are with Chevron Energy Solutions, San Francisco, CA 94104 USA (e-mail: EAAE@chevron.com; Tim.Brown@chevron.com; Erin.Minear@chevron.com).

R. H. Lasseter is with the University of Wisconsin, Madison, WI 53706 USA (e-mail: lasseter@engr.wisc.edu).

Color versions of one or more of the figures in this paper are available online at <http://ieeexplore.ieee.org>.

Digital Object Identifier 10.1109/TSG.2013.2286575

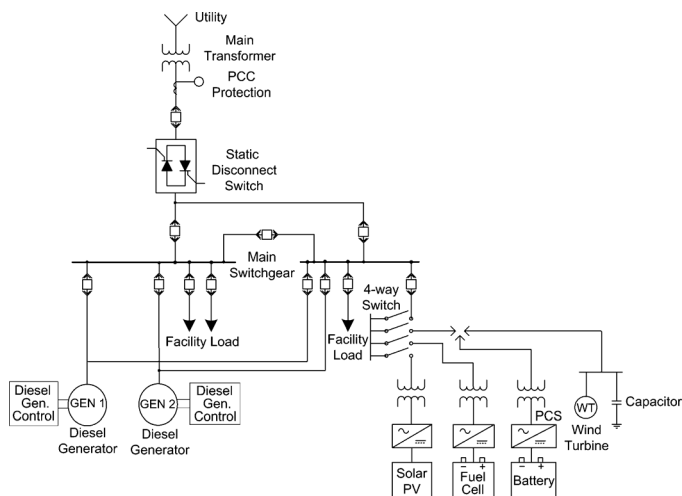

Fig. 1. Santa Rita Jail Microgrid Single Line Diagram.

frequency itself is not as stable as the grid and may trigger anti islanding functions on PV or Fuel Cell inverters to trip the equipment offline. This is a disadvantage from an economic and environmental perspective because the clean, renewable sources were not being utilized during island conditions. Upon restoration of utility power the fuel cell would take several hours to restart, resulting in increased demand and energy charges on the utility bill. The solar photovoltaic and fuel cell operation also was impacted by utility power quality events such as voltage sags, [8], [9]. These impacts related to utility issues were resolved with incorporation of a fast static disconnect switch (SDS), which enabled autonomous operation and seamless islanding of the Jail. The Jail's ability to autonomously island was key to providing the highest system reliability. Due to the practical limitations of matching the existing generation and load for a successful island transition, advanced energy storage (battery) was utilized to stabilize system voltage and frequency during transient conditions. Using CERTS Microgrid protocol aided in simplifying the integration of the battery and SDS with existing on-site resources. The "plug-and-play" nature of the CERTS protocol gives CERTS-based sources (diesel generators and battery) the ability to interconnect with each other without the need for a customized supervisory generator control system.

In addition to the battery providing system reliability and stability, it would also be used to optimize on-site generation to decrease the total cost of energy purchased from the utility. The current utility tariff schedule has time-of-use rates under which energy consumption and maximum power demand vary based on time of day and season. The battery can store energy purchased during less-expensive off-peak periods to be utilized during peak periods.

III. THE CERTS CONCEPT

One of the objectives of the CERTS Microgrid concept was to reduce microgrid system cost and increase reliability. This includes *plug-and-play* functionality without communications. Plug-and-play concepts reduce engineering cost and errors

since little site modification is required for different applications. Each CERTS device regulates voltage and frequency both grid connected and while islanded. These key concepts have been demonstrated at the American Electrical Power Microgrid Test Facility. This includes such transient events such as seamless separation and automatic re-synchronizing with the grid, Class I level power quality during utility faults, large unbalanced loading and stable operation during major events [5]. The CERTS concept has three critical components: the static disconnect switch, the micro-sources, and loads. The static disconnect switch has the ability to island the microgrid autonomously for disturbances such as faults, IEEE 1547 events or power quality events. Following islanding, the reconnection of the microgrid is achieved autonomously after the tripping event is no longer present. Resynchronizing to the utility uses the frequency difference created by the islanding event [6].

Each CERTS-controlled source seamlessly balances the power on the islanded microgrid using a power vs. frequency droop controller. In this project the battery storage system and the backup diesel generators have the CERTS frequency and voltage control. The fuel cell and the photovoltaic inverters run in a power mode and do not track load, control voltage or frequency. For example, if the load increases while in island operation, the storage system will provide the extra power instantaneously and reduce the operational frequency. At maximum output the frequency controls are designed to drop no more than 1%. If there is inadequate energy to meet the load, the frequency will drop below the normal operating range, signaling the non-critical loads to shed. The coordination between sources and loads is through frequency.

The storage inverters and the diesel generators not only control the voltage but they also ensure that there are no large circulating reactive currents between units. With small errors in voltage set points, the circulating current can exceed the ratings of the units. This situation requires a voltage vs. reactive power droop controller so that, as the reactive power, Q , generated by the unit becomes more capacitive, the local voltage set point is reduced. Conversely, as Q becomes more inductive, the voltage set point is increased. At Santa Rita Jail this droop is 5%. In addition to the system voltage stability demonstrated at the AEP test site extensive analyses indicates that microgrid's stability is independent of the number of CERTS devices in a microgrid [7]. Theoretically the system remains stable as we approach an infinite number of CERTS units.

The CERTS Microgrid controls do not rely on a "master" controller or source. Each source is connected in a peer-to-peer fashion with a localized control scheme implemented for each component. This arrangement increases the reliability of the system in comparison to having a master-slave or centralized control scheme. In the case of master-slave controller architecture, the failure of the master controller could compromise the operation of the whole system. Santa Rita Jail uses a central communication system to dispatch storage set points, voltage and power as needed to control the state of charge. However, this communication network is not used for the dynamic operation of the Microgrid. This plug- and-play approach allows for expansion of the Microgrid to meet the requirements of the site without extensive re-engineering. Plug-and-play implies that a

unit can be placed at any point on the electrical system without re-engineering the controls, thereby reducing the chance for engineering errors.

IV. DESIGN IMPLEMENTATION

The key considerations for the Microgrid system design were meeting the criteria for operation under the CERTS protocol and integrating with the existing infrastructure.

A. Battery

The battery technology selected for this project was a 2-MW, 4-MWh Lithium Iron Phosphate (LiFePO_4) battery. This is a type of lithium ion battery that uses LiFePO_4 as a cathode material. Several battery technologies were compared during the design process. Some of the highly weighted selection criteria included round trip efficiency, cycle life, maximum temperature rating, safety, environmental considerations, and maintenance requirements. Compared with other lithium-ion battery chemistries, the LiFePO_4 battery offers improved safety because of the thermal and chemical stability exhibited by the technology. The tradeoff is a slightly lower energy density than other lithium ion chemistries. The specified AC-AC round trip efficiency was 85% while the actual measured AC-AC round trip efficiency was 88%.

The energy stored in the battery can be used either for tariff-based rate arbitrage or power quality and reliability. When grid connected, the battery can charge or discharge as dictated by the Energy Management System in order to maximize the economic benefit of the battery. The rate arbitrage scheme is based on the utility tariff structure and not on real time pricing. During a grid disturbance or outage, the energy in the battery is used to continuously supply high quality power to the on-site loads.

The battery was sized at 2 MW, 2.5 MVA to be able to serve the facility demand, which peaks at 2.8 MW, 2 MVARs in the summer afternoons. This would allow the facility to island from the utility grid when the fuel cell or part of the PV system are on-line, but may require load shedding in the unlikely event that all PV inverters and the fuel cell are off-line.

The 4-MWh storage capacity was sized such that on a typical summer day the battery, fuel cell and solar photovoltaics could serve all of the facility peak-period energy usage. 80% of storage capacity is used for rate arbitrage, reducing the facility peak load. The remaining 20% is reserved for power quality events when the system transitions from grid connected to island operation. This provides enough energy to maintain the system until the diesel generator starts, if required. The battery has an upper and lower state-of-charge limitation of 90% and 10% respectively during grid connected operations to maintain the reserve for power quality. To ensure reliability during island operation a new load and generation management system will control the shedding and adding of load and generation sources (i.e., PV generation or fuel cell) in order to prevent the battery from reaching a full charge or discharge state and shutting down.

B. Power Conversion System

A CERTS-compliant power conversion system (PCS) was required to interface the battery with the Microgrid and utility source. The installed PCS is rated 2 MW, 2.5 MVA, consisting

of four DC-to-DC converters that interface with each of the four 500-kW, 1-MWh battery enclosures. Each of the battery enclosures is independent and capable of operating if any or all of the other three containers are shut down. There are two DC-to-AC inverters that interface with two DC-to-DC converters, each through a common DC link bus. This system architecture makes the system highly flexible, allowing for proper maintainability and testing. The PCS was sized such that it could supply some, but not all of the facilities reactive power needs. This is discussed further in the capacitor bank section.

When grid-connected, the EMS dispatches charge or discharge signals to the PCS to provide the highest level of economic benefit to the Jail. To change the rate of power charge or discharge, the PCS responds to “raise speed” or “lower speed” signals, similar to those used in frequency/load control of traditional generation units. The PCS frequency droop curve moves up or down, without changing its slope, thus changing the rate of power charge or discharge of the battery. Similarly the reactive power flow is controlled with the voltage droop curve.

During the transition from grid-connected to island, the PCS remains connected, operating as a voltage source, even if the voltage and/or frequency are outside normal operation limits. The transient recovery voltage period is typically within one cycle, but may last several cycles depending on the circumstances of the islanding process. During this time, the PCS is constrained only by its internal current and power limiting functions.

When the Microgrid is islanded, the CERTS algorithm programmed in the PCS determines the appropriate battery charge and discharge levels within the range established by the frequency and voltage droop curves of the PCS [10].

During passive synchronization with the utility, the PCS is required to remain online even with a wider delta V and Delta F synchronization window than traditionally used.

C. Capacitor Bank

The Jail currently has high reactive power demand due to large rotating loads. This large reactive demand coupled with the on-site renewable sources operating near unity power factor led to a low power factor at the utility point of common coupling. Reactive power compensation would be needed in order to avoid low power factor penalties on utility billing. More importantly, according to a dynamic analysis study, the Microgrid would not be able to island successfully without another reactive power source supplying the rotating equipment. An economic analysis revealed that a capacitor bank was the preferred alternative for supplying the reactive power needs compared to increasing in the PCS MVA rating. A 900-kVAR capacitor bank was installed to provide the remaining reactive power to allow the Microgrid to island.

D. Static Disconnect Switch

A static disconnect switch (SDS) was installed between the utility and Microgrid to allow for very fast islanding and autonomous operation of the Microgrid. There are voltage and current transformers on the line and load sides of the SDS to constantly detect the voltage and frequency of both the utility

TABLE I
PROTECTION SETTINGS FOR THE STATIC DISCONNECT SWITCH.

Protective Function	Device Design Range	Implemented Value
Overvoltage	105 – 115%	115%, 10ms (Fast) 110%, 2ms (Instantaneous)
Undervoltage	95 – 80%	80%, 10ms (Fast) 50%, 3ms (Instantaneous)
Overfrequency	60.1 – 63 Hz	60.5Hz, 0.5ms
Underfrequency	59.9 – 57 Hz	59.5Hz, 0.5ms
Directional Overcurrent	0 – 500%	130%, 60 sec

and Microgrid systems. These measurements allow the system to island during power failures or power quality events exhibited by the utility. The SDS operates within a quarter cycle on the order of 4 to 10 milliseconds. Disconnection and islanding from the utility are fast enough that any utility events go undetected by the inverter sources in the Microgrid.

The SDS is rated 12.47 kV, 60 HZ, three-phase, with a BIL of 95 kV, for use on a 4-wire solidly grounded system. It has a continuous and load interrupting rating of 300A and an overload rating of 375A (125%) for 120 seconds. The unit thyristor valves have the capability to withstand the surge current of 35 kA for one cycle and 8kA RMS symmetrical for fifteen (15) cycles. It was designed to operate with N + 2 redundancy on the thyristor valve devices. This allows the SDS to operate with two thyristor levels shorted out. The overall efficiency is 99% or greater.

The SDS contains islanding and synchronization functions compatible with CERTS protocols. This requires passive synchronization, without the need for external signals for islanding or synchronizing.

Islanding operations are triggered by overvoltage, undervoltage, overfrequency, and underfrequency. There is also directional overcurrent, with current flowing towards the utility grid, required by the utility, programmed in the external protective relay that trips the main 12 kV utility breaker. These functions are coordinated with revised overvoltage, undervoltage, overfrequency and underfrequency settings in the fuel cell inverters and PV inverters to ensure that all renewable generation stays online following and islanding transient. The protective setting ranges and implemented values for islanding are listed in Table I.

This SDS was installed in conjunction with bypass and isolation switchgear to allow for servicing of the unit and shutdown in case of any failures.

E. Diesel Generator Upgrade

Santa Rita Jail currently has two 1.2-MW backup diesel generators. These diesel generators would operate only when there was a utility power outage. As part of the Microgrid, the generators are now operated to charge the battery if the battery has a low state of charge when islanded or if the Microgrid fails. This significantly reduces the operation time of the diesel generators... The old speed and voltage controls of the diesel generators were isochronous, meaning they maintained a constant frequency and voltage over any real and reactive power output, within the generators' rated capacity. The controls were modified and upgraded to be CERTS-compliant. CERTS compliant

means allowing voltage and frequency droop operation, similar to the operation mode used when operating diesel generators synchronized with the utility grid. Since controllers to operate reciprocating engine-generators synchronized to the utility grid are readily available, off-the-shelf generator control equipment was used for the diesel generator control upgrades, avoiding the need for costly special-design equipment. This is one of the advantages of using CERTS; it simplifies the integration of renewable or large-scale energy storage equipment with conventional generation.

The Santa Rita Jail backup diesel generators are not permitted by air quality regulations to operate when utility power is available. When the microgrid islands due to a utility outage and the diesel generators are called into operation, the generators synchronize with the microgrid and operate in voltage and frequency droop mode (CERTS mode). In this mode of operation, the kW output of the diesel generators are controlled by biasing the frequency droop curve, without changing its slope, until the desired kW output is achieved. Again, this is similar to the strategy used to control kW output of conventional generators when operating synchronized to the utility grid. To minimize the operating hours of diesel generators during a sustained utility outage, the diesel generators are only called into operation when needed; that is when the battery state of charge reaches a minimum island-operation set-point. In addition, when operating in parallel with the microgrid, the kW output of the diesel generators is set to operate close to its rated output, where the operation is most efficient. However, by operating below rated output, there is margin in the output for the diesel generators to share frequency and voltage control functions with the battery per their respective voltage and frequency droop curves. The generators transition back to isochronous control in the event the Microgrid is not operational; that is when the battery is out service. In this case, the system operates just like a traditional backup generation system, the utility power outage would cause a brief power outage in the facility, followed by isochronous operation of the backup diesel generators.

F. Energy Management System

A centralized control system was installed at Santa Rita Jail to optimize the use of the on-site generation sources when grid-connected based on the applicable utility energy rates [11], [12]. This system monitors power flow at various points to determine system loads and available generation. The EMS controls the flow of power across the Point of Common Coupling (PCC). Depending on the actual time-of-use rate (in this project they are peak, partial peak, and off-peak) the EMS will determine its control strategy. For example, during off-peak the system's goal is to charge the battery to a maximum SOC while not setting a new demand peak. The calculation parameters, which are utilized in an algorithm, include predicted average demand load, the available discharge energy from the battery, and the required average charge of the battery. The power flow at the PCC is determined as a function of tariff rate structure, predicted generation profiles, and historical load profiles. Thus the EMS gives the battery extra functionality to reduce operating costs while still maintaining high system integrity and reliability.

G. Systems Studies

Extensive system studies were performed to better understand the dynamic response of the microgrid. A PSLF model of the Santa Rita Jail system, that included the dynamic models of the battery system, the diesel generators and rotating loads, was completed. The PSLF model also included a thyristor-based switch at the PCC (modeled as a switching element able to respond in 10 milliseconds) and elements of the system that do not have a dynamic response to changes in voltage and frequency like the capacitor banks, the fuel cell, the photovoltaic systems, cables, static loads, etc. See Fig. 1. The PSLF model was verified with dynamic response tests performed during the PCS factory acceptance test and during commissioning tests at the Santa Rita Jail site.

As an example consider the transient when the two diesel generators are introduced to charge the storage system while in island operation. In this case the storage autonomously moves from maximum output of 2 MW to charging while increasing the island's frequency by approximately 1/4 Hz.

The top two plots in Fig. 2 show the real and reactive power for the storage system, the pv, the fuel cell, the capacitor bank and the diesels. The lower two plots are phase-a current and voltage waveforms for the diesels and storage inverter. Before the diesels are introduced the storage is discharging at 2 MW. At time = 0 seconds the generators are connected. Once connected, the power-transition between the battery and the generators occurs over approximately one second. The power oscillations seen here are a result of a non-zero load-angle during synchronization. The inertia of the diesel results in power fluctuations as the power accelerates and decelerates as a function of the position, resulting in a classical second-order response.

The synchronization process is evident from the relative blurring of the voltage waveform prior to $t = 0$ and subsequent alignment of the voltage waveforms after synchronization. The power increase from the gensets and the subsequent reversal of power flow from the storage system is also evident in these figures. These voltage wave forms also demonstrate the robustness of the voltage controller during this event.

V. COMMISSIONING TEST AND LESSONS LEARNED

A. PCS Factory Acceptance Test

To ensure successful commissioning at the site, a complete test of the CERTS functions of the PCS was performed at the factory before shipping. This factory acceptance test included both island and grid-connected operation in CERTS mode. In island operation, the PCS operated alone with a real and reactive power load bank and in parallel with a diesel generator operating in voltage and frequency droop mode. The simplicity of integrating CERTS-capable inverters with other resources operating in voltage and frequency droop was apparent at the factory acceptance test. An off-the-shelf diesel generator was integrated easily with a CERTS-capable inverter. There were no complications other than appropriately setting the droop voltage in the voltage regulator and the droop frequency in the engine governor. During the factory acceptance test, the two sources appropriately shared real and reactive power with no communication lines between the two. The speed at which the PCS adjusts

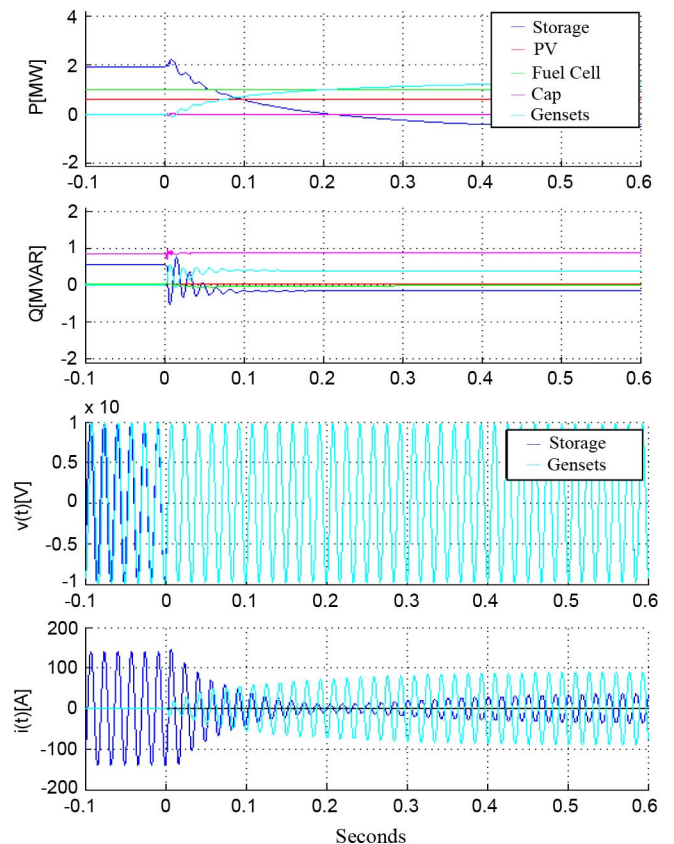

Fig. 2. Simulation of Starting Generators while Islanded.

its real and reactive power output on islanding also was verified, within 20 milliseconds for both real and reactive power. The CERTS protocol allows seamless islanding because of the ability of a CERTS-capable inverter to change its real and reactive power output upon sensing frequency and voltage variations at its terminals. Seamless island tests without communication between the utility interconnection breaker and the PCS were demonstrated at the factory acceptance test, even when the PCS was required to change from discharge to charge mode or vice versa (i.e., from positive to negative real power flow).

B. Site Acceptance Test

The system also had to be tested at the site with all of the existing distributed energy resources and the SDS. Once the PCS and the battery enclosures were installed and integrated, island tests of the battery system and the fuel cell with a load bank were completed without including the facility load. However, these tests did not yet include parallel operation of the Santa Rita Jail diesel backup generation system. Once the battery had demonstrated reliable grid-connected operation and island operation with the fuel cell and load bank, a whole-facility island test was scheduled. This whole-facility island test had to be witnessed by Pacific Gas and Electric (PG&E), the local electric utility, as part of the utility's routine pre-parallel inspection process, which any conventional generator has to complete. At that point all of the protective functions required by PG&E were successfully demonstrated and Santa Rita Jail was seamlessly islanded and resynchronized with PG&E for the first time. Only after this had been completed could island operation of the battery,

in parallel with the facility diesel backup generation system, be tested. The controls of the diesel backup generation systems had previously been modified to allow voltage and frequency droop operation. The diesel generators with their modified controls were tested and appropriate real and reactive power sharing was demonstrated. This was done at different transient conditions that included battery discharging and charging using diesel generator power.

C. Lessons Learned

Utilities are not yet very familiar with the use of static disconnect switches as a disconnection device at the point of common coupling (PCC). Until SDSs become more common and standards for their use as a PCC disconnection device are developed, conventional equipment must be used to satisfy utility interconnection requirements. In the Santa Rita Jail Microgrid case, a standard 12-kV vacuum breaker and conventional utility-grade protective relays were used upstream from the SDS. Since the SDS operates much faster than conventional equipment in the islanding process (in 8 milliseconds or less), the conventional equipment only operates in the event of SDS failure or when the SDS is out of service and bypassed. In the resynchronization process, after the electric utility restores service, the SDS synchronization function is supervised by a conventional synch-check relay (device 25).

On the battery side, the integration of the battery enclosures and PCS has to be carefully managed. The Battery Management System (BMS) that manages and monitors the condition of the batteries in the battery enclosures needs to communicate with the PCS to report state of charge (SOC), charge and discharge limits, malfunctions, alarms, etc. It may be a challenge to achieve reliable communication in the noisy environment created by fast switching power electronics. Also, accurate SOC reporting is key in a battery system that is charged and discharged daily for rate arbitrage, but also needs to leave energy available for power quality functions.

In a Microgrid system that has so many functions, an overarching control system such as the one employed on this project is an important component. The Energy Management System has different priorities depending on the system operating mode. In grid-connected operation, EMS controls minimize electric power costs while ensuring that enough energy is available in the battery for the power quality functions. In island operation, EMS controls maximize reliability, starting the diesel generators at low SOC and shedding generation as appropriate at high SOC. This is done with the purpose of keeping the battery continuously operating with safe margins in island mode. EMS also has an archive system that records a variety of information, including energy consumption by feeder, real and reactive power flow, power quality monitoring, battery condition, etc. This archive system has proven to be an important tool in improving the system performance. After reviewing archived information, the settings that control grid-connected and island operation were adjusted to improve the benefit the battery provides to the facility. There is still much to be learned about maximizing the benefit that a battery system can provide. The EMS archive system will continue to provide information to support additional improvements.

As was expected, the CERTS protocol simplified the integration of conventional generation equipment with the large-scale energy storage system. This is because the CERTS protocol actually does not require any communications between the large-scale energy storage system and the conventional generation equipment, as long as the large-scale energy storage system follows the CERTS protocol and the conventional generation equipment operates in droop mode. The voltage and the frequency at the terminals of the equipment provide all the communications required for the system to operate and share real and reactive power between conventional generation and the large-scale energy storage system appropriately. This characteristic of the CERTS protocol not only adds simplicity, but also improves reliability. When function beyond simple sharing of real and reactive power are required, like charging or discharging of the large-scale energy storage system at a certain level, at a certain time, these are achieved with simple programming and low speed communication between off-the-shelf designed to control conventional generation that needs to be part of the generation system anyway. This results in lower integration cost and lower communication/control hardware and software cost compared to systems that do not use the CERTS protocol and droop operation, and require sophisticated, high-speed communications among the different elements of the system.

VI. NEXT STEPS

The commissioning test results and system performance monitoring will outline the path forward to further enhancing the CERTS Microgrid operation.

A new load-shedding system will be installed. In Microgrid island mode, the new scheme will have traditional frequency-based shedding. It also will have the ability to control the load and solar photovoltaic, fuel cell, and diesel generation by shedding and adding based on the battery state of charge. In grid-connected mode, the system has the ability to accept an external load curtailment command as a part of a utility demand-side management program.

Future analysis of the battery performance will help in refining operational set points. The current maximum and minimum battery SOC limits used in the grid-connected dispatch algorithm leave a margin of capacity to account for the difference between the predicted and real-time load and generation profiles, plus leave spare capacity to be used in the event of a utility power outage. Refining these values will further optimize battery usage.

The CERTS Microgrid also has the potential to support the grid with ancillary services. The increasingly high penetration of renewable power such as solar photovoltaic and wind put the grid at risk of sudden and unpredictable power fluctuations due to shifts in weather conditions. The Independent System Operator (ISO) is looking for fast-ramping sources such as batteries that can provide frequency regulation to help increase the stability of the grid.

VII. CONCLUSIONS

The CERTS protocol has proven to be a powerful tool for integrating distributed energy resources. This first became apparent at the PCS factory acceptance test and later on-site during

commissioning and operation of the system. Only minor modifications in the existing diesel backup generation systems were needed to allow it to operate in parallel with the CERTS-capable battery.

Until SDSs are more common and standards are further developed for their use as PCC disconnection devices, conventional equipment like electromechanical breakers and conventional protective relays will continue to be used to satisfy utility interconnection requirements for Microgrids.

Even when CERTS-capable distributed energy resources can operate without necessarily having communication among them, an overarching control system like EMS is necessary to maximize the benefit of a battery system. EMS should include an archive system to provide the information needed to make continued improvements on the system.

The accurate data supplied by the battery management system provides information needed by EMS to adequately manage the battery system. This becomes more important in a battery system that is charged and discharged daily.

To improve the reliability of the Microgrid during island operation, especially at high and low battery state of charge, a load and generation shedding scheme should be considered. It is critical to keeping the battery operating with safe margins and to ensure the reliability of the Microgrid island operation.

APPENDIX EQUIPMENT SUMMARY

Equipment	Rating	Microgrid Function
Static Disconnect Switch	12.47kV, 300A	Separate from grid upon disturbance
Capacitor Bank	12.47KV, 900KVAR	Provide reactive power during grid connected and island operations
Battery + PCS	Battery – 2MW, 4MWh PCS – 2MW, 2.5MVA	Support transition from grid connected to island; reduce facility peak demand and energy usage
Diesel Generator	(2) 1.2MW	Support island operation when battery is at low state-of-charge
Fuel Cell	1MW	Supply power to facility in grid connected and island operation
Solar PV	1.2MW	Supply power to facility in grid connected and island operation

REFERENCES

- [1] R. H. Lasseter, "Control of distributed resources," in *Proc. Bulk Power Syst. Dynamics and Control IV; Restructuring*, Santorini, Greece, Aug. 23–28, 1998.
- [2] R. Lasseter, A. Akhil, C. Marnay, J. Stephens, J. Dagle, R. Guttromson, A. S. Meliopoulos, R. Yinger, and J. Eto, in *Proc. Integration of Distributed Energy Resources: The CERTS MicroGrid Concept*, Apr. 2002.
- [3] R. H. Lasseter, "CERTS Microgrid," in *Proc. IEEE Int. Conf. Syst. Syst. Eng., 2007 (SoSE'07)*, Apr. 16–18, 2007, pp. 1–5.
- [4] J. Eto, R. Lasseter, B. Schenkman, J. Stevens, H. Volkommer, D. Klapp, E. Linton, H. Hurtado, J. Roy, and N. Lewis, *CERTS Microgrid Laboratory Test Bed. (California Energy Commission CEC-500-03)*. : , 2008.

- [5] R. H. Lasseter, J. H. Eto, B. Schenkman, J. Stevens, H. Volkommer, D. Klapp, E. Linton, H. Hurtado, and J. Roy, "CERTS Microgrid Laboratory Test Bed," *IEEE Trans. Power Delivery*, vol. 26, Jan. 2011.
- [6] R. Lasseter and P. Piagi, "Microgrid: A Conceptual Solution," in *Proc. PES'04 Aachen*, Germany, Jun. 20–25, 2004.
- [7] M. Illindala and G. Venkataramanan, "Small Signal Dynamics of Inverter Interfaced Distributed Generation in a Chain-Microgrid," in *Proc. IEEE PES General Meeting*, Jun. 24–28, 2007.
- [8] Government County of Alameda, California, Santa Rita Jail Fuel Cell Power Plant (ND) [Online]. Available: <http://www.acgov.org/sustain/documents/fuelcellfactsheet.pdf>
- [9] C. Dierckxens, Valuation of the Santa Rita Jail Photovoltaic Array, Traineeship Report Katholieke Universiteit Leuven, 2009.
- [10] M. Erickson and R. Lasseter, "Integration of battery energy storage element in a CERTS microgrid," *Proc. IEEE ECCE*, Sep. 2010.
- [11] C. Marnay, N. DeForest, M. Stadler, J. Donadee, C. Dierckxens, G. Mendes, J. Lai, and G. F. Cardoso, "A green prison: Santa Rita jail creeps towards zero net energy (ZNE)," in *Proc. ECEEE*, 2011.
- [12] N. DeForest, M. Stadler, C. Marnay, and J. Donadee, "Microgrid dispatch for macrogrid peak-demand mitigation," *Proc. ACEEE Summer Study on Energy Efficiency in Buildings*.

Eduardo Alegria received the M.S. degree in electrical engineering from the California Polytechnic State University San Luis Obispo, CA, USA, in 1990.

He worked for PG&E and PG&E Energy Services in Power Generation and later as the supervisor of the Power Quality Group. With PG&E Energy Services he developed the first application of 25 kV class static transfer switches. He joined Chevron Energy Solutions, San Francisco, CA, USA, in the year 2000. He works in the areas of power system reliability, power generation interconnection, large scale energy storage, microgrids, and power system stability.

Tim Brown received the B.S. degree (*summa cum laude*), and the M.S. degree (with distinction) in electrical engineering from California Polytechnic State University in San Luis Obispo, CA, USA.

He has worked as a Project Engineer at Chevron Energy Solutions, San Francisco, CA, USA, since 2009. His work involves solar photovoltaics, advanced energy storage, energy efficiency, power reliability, and power system protection.

Dr. Brown is a registered professional engineer in the state of California.

Erin Minear received the B.S. and M.S. degrees in electrical engineering from California Polytechnic State University San Luis Obispo, CA, USA.

She has worked as a facilities engineer at Chevron Energy Solutions, San Francisco, CA, USA, since 2007. Her work involves power system reliability, power system protection, energy efficiency, advanced energy storage and solar photovoltaic system design.

Dr. Minear is a registered professional engineer in the state of California.

Robert H. Lasseter (F'92) received the Ph.D. degree in physics from the University of Pennsylvania, Philadelphia, PA, USA, in 1971.

He was a Consulting Engineer at General Electric Co. until he joined the University of Wisconsin-Madison, WI, USA, in 1980. His research interests focus on the application of power electronics to utility systems and technical issues which arise from the restructuring of the power utility system. This work includes interfacing micro-turbines and fuel cells to the distribution grid, Microgrids, control of power systems through FACTS controllers, use of power electronics in distribution systems and harmonic interactions in power electronic circuits.

Prof. Lasseter is a Fellow of IEEE, and an IEEE Distinguished Lecturer on Distributed Generation.