

MARKETS FOR REACTIVE POWER AND RELIABILITY: A WHITE PAPER

Engineering and Economics of Electricity Research Group (E³RG)

CORNELL UNIVERSITY

E³RG contributing authors:

Robert Thomas, Director

Faculty and Research Associates: Timothy Mount, Richard Schuler,
William Schulze, Ray Zimmerman

Graduate Assistants: Dan Shawhan, David Toomey

This project was supported in part by the US Department of Energy through the Consortium for Electric Reliability Technology Solutions (CERTS) and in part by the National Science Foundation Power Systems Engineering Research Center (PSERC). Additionally we would like to thank Duane Chapman, Daniel Tylavsky, George Gross, Fernando Alvarado, Joe Eto, Shmuel Oren, Phil Overholt, and the army of past and present students who worked on parts of this project over the years for their support and for helpful comments during the course of this work. All conclusions, recommendations, and remaining errors are the sole responsibility of the authors.

Executive Summary

The FERC report on reactive power clearly and succinctly lays out the issues and raises important questions about market power, contingent-claim versus real-time markets, the need for an optimal power flow that incorporates reactive power, etc. Unfortunately, the economic/engineering models so far available in the literature fail to represent the true economic optimum. This optimum involves maximization of the expected net benefits of electricity production, transportation, and use under the constraint of a full alternating-current (AC) power flow where the expected net benefit is defined as the sum of the probability-weighted economic outcomes for all contingencies, including line and generator failures. This is the correct way, in terms of economics, to determine optimal reliability, levels of investment, and operation parameters under alternative contingencies, as well as efficient and optimal production and prices for real and reactive power.

The purpose of this paper is to take a broad look at how markets should be organized, not only for reactive power but for real power and reliability, since these markets are fundamentally interdependent and essential for efficient and reliable delivery of electric power.

To accomplish this end, the paper opens with specification of an economic/engineering model of optimal investment and operation that is then simulated so that principles and goals for optimal market design can be established. The paper then examines issues of market power through both simulation and experimental economics. Finally, a variety of possible market designs are presented and evaluated in light of the conclusions drawn from the conceptual model, simulations, and experiments. The paper concludes with specific recommendations.

The conclusions drawn from the research are:

- 1) Although network reliability has long been identified as a public good, voltage and frequency have not been so identified. The modeling and simulations presented here using AC power flows demonstrate the public-good nature of voltage and reliability of lines. Note that, except under special circumstances, private incentives for provision of public goods are insufficient and efficient provision requires some central authority.
- 2) Both real power and reactive power are technically private goods since they are excludable and rival. Thus, unlike voltage and reliability, well-designed private markets are theoretically efficient if the public goods needed to support the system are optimally provided.
- 3) Simulation of optimal operation under different contingencies demonstrates that nodal reactive-power prices are almost always equal to zero if optimal investment in reactive-power

sources (e.g., generators and reactive-power compensators) occurs throughout the system. Nonzero reactive-power prices, which optimally are found only during contingencies, such as when failures occur, remain relatively low because of the low cost of investment in a reactive-power supply.

4) The average or expected revenue derived from sales of reactive power at optimal real-time prices during rare contingencies is sufficient to provide incentives for optimal private investment in reactive-power capacity. However, this is a highly volatile and uncertain source of revenue that depends on such rare contingencies actually occurring. Thus, private investments in reactive capacity are inherently risky investments. Note that when reactive capacity is in short supply the willingness-to-pay, or social value, of reactive power is many orders of magnitude greater than investment based on cost per unit during contingencies, so it is optimal to make large investments in reactive-power capacity to prevent shortages even during rare contingencies.

5) However, both simulations and economics experiments show that opportunities for the exercise of market power by private suppliers of reactive power in real-time markets are plentiful in a network environment in which transmission of reactive power is limited to short distances, as established by Kirchoff's laws. Thus, even with sufficient reactive-power capacity, suppliers are likely to submit offers that will produce positive real-time reactive-power prices in noncontingency states for which optimal prices are zero.

6) Whereas virtually all demand for real power comes from private buyers (losses in the transmission network are small, on the order of 2-3%), demand for reactive power comes from two sources: (1) demand from private buyers to meet the needs of motors, arc welders, and other equipment that require a magnetic or electric field to operate and (2) the often greater demand from a central authority, acting in the public interest, for reactive power as an input to provision of a public good—voltage. We include in this category the often large amount of reactive power consumed by transmission lines that are operating far from their surge impedance loading. Thus, since voltage is essential for reliability, reactive power plays a special role in the security of the power system.

7) Optimal real-power prices show greater upside volatility than optimal reactive-power prices, principally because investment in generation is so expensive that it cannot optimally cover all contingencies. Optimal generation investment does conform to the conventional wisdom of covering the worst single contingency by meeting load after the loss of the “largest” generator in the simulation. However, peak prices during some contingencies are much higher for real power because optimal investment in capacity cannot efficiently cover load with the loss of multiple generators. Note that optimal investment will occur in a free market only when prices are not capped since the next-to-worst-case scenario for generator failure provides the incentive for investment in the surviving generator to provide optimal reliability through prices on the order of \$10,000 per megawatt hour.

8) Optimal investment in lines in the simulation is sufficient so that thermal line constraints are never binding, even during contingencies. Thus, if a lossless DC optimal power flow were used there would never be nodal price differences that could be used for, for example, transmission fees. Using a full AC power flow does, however, show substantially different nodal prices for

both real and reactive power, but only during contingencies. There can be no transmission fees from nodal price differences for real and reactive power unless prices are computed from a full AC optimal power flow. These prices are needed to provide both revenue and charges for reactive power consumed by lines (to maintain voltage) that will generate optimal incentives for line investment.

Based on these research conclusions, we recommend the following:

- 1) The first conclusion presented—that some central authority is needed to provide the public goods of reliability and voltage (as well as frequency)—implies that electric power does not lend itself to the degree of decentralized decision-making that is common in other markets. Thus, there must be some institution that has government-like authority to design, plan, and manage the system. This entity is referred to as the central authority because current independent system operators do not have authority for planning and design.
- 2) For the central authority to act in the public interest and be able to optimize the system, as well as provide necessary public goods, the central authority must possess a robust *AC Optimal Power Flow* (AC OPF) program that can resolve real- and reactive-power problems properly. The program should include unit commitment, ancillary services, and contingencies. A proper AC OPF is needed to give an accurate picture of the system for operations, as well as accurate price information for real power, reactive power, and transmission. Such prices are necessary as a basis for proper investment decisions in generation, reactive compensation, and transmission. A major research and development program should be undertaken to provide this capability.
- 3) The third conclusion states that reactive-power prices will be mostly zero with appropriate investment in reactive compensation. When a real-time market for a private commodity has financial transactions on rare occasions and, because markets are expensive to operate, natural economic forces will restructure the market to avoid transaction costs. The commodity used in these markets is called a contingent claim, which is a claim for services that can be made only if one or more specified events occur. Contingent-claim markets, which are appropriate for reactive power, operate well in advance of the contingencies that justify claims and are the normal replacement for real-time markets, which rarely have transactions. In a contingent-claim market, the central authority essentially rents major reactive-power sources from suppliers that submit the lowest-priced offers and instructs the suppliers in how to operate those sources in real time. For generators, the contingent-claim contract can provide fixed compensation for reductions in real-power output if reactive-power needs require such reductions.
- 4) Because the central authority responsible for reliability and operations needs reactive power on demand so that it can deal with contingencies and thereby assure reliability (conclusion 6) and because the substantial investment required to meet that demand must be assured in advance (conclusion 4), the reactive-power market must be run well in advance of any contingency to assure needed supply. Contingent-claim markets are appropriate for reactive power because they close well in advance of any claims made and, if run sufficiently far in advance, can provide a sure source of revenue, encouraging investment. Rather than obtaining revenue through unpredictable rare contingencies, sources that submit winning offers obtain steady revenue in the form of rent to compensate them for providing reactive power on demand. Note that, since this

market is run far in advance, the central authority must project the amount of reactive power capacity needed for private buyers and to maintain voltage. Thus, based on the central authority's determination of how much reactive power will be needed and where (projected nodal demand), this market must be run locally to efficiently acquire reactive-power sources.

5) Market power is a serious problem for the supplying of reactive power (conclusion 5) in real-time markets, more critical than in the case of real power. The overall demand for reactive power comes in great part from the central authority responsible for system operations and providing reliability to meet public needs. Competitive prices will be assured in contingent-claim auctions only if some offered units are potentially excluded. We recommend that contingent-claim auctions for reactive power be run sufficiently far in advance to allow construction to occur (three to five years) so that existing suppliers are placed in competition with potential investors and new sources of reactive power, encouraging competitive prices.

6) Although real-time markets for real power are potentially feasible and can provide stable revenue for investment in generation through forward markets (as the Australian example suggests), capped real-power prices paid to generators, as is common in U.S. power markets, will not provide sufficient incentives for investment in generation to assure optimal reliability. Thus, we support measures to supplement generation investment if prices to generators are capped. Although a number of approaches are being tried to encourage investment in generation, it is not yet clear if any are successful or cost-effective.

7) The central authority responsible for reliability and operations must have legal authority to impose the stringent penalties necessary to enforce contracts purchased in contingent-claim markets.

8) To provide incentives for conservation of real- and reactive-power demand, large customers and marketers should pay real-time nodal prices for real and reactive power as derived from the system AC OPF. Contingent claim markets are appropriate for the supply side of the reactive power market, but real time nodal prices are appropriate for sales to marketers since they will then have incentives to install metering and then either pass on real-time prices or install automated controls on customer equipment in exchange for a lower fixed rate. This will also make distributed energy resources and load response much more economically viable.

9) Nodal prices from a DC power flow can provide incorrect price signals, including indicators for investment in lines. Proper incentives require that transmission fees be equal to the nodal price differences for real and reactive power derived from a full AC power flow and be applied to transmission of both real and reactive power. Transmission must also pay for reactive power consumed by lines. Note, however, that transmission fees typically may be near zero with optimal line investment but tend to be positive during contingencies. As in the case of reactive-power markets, real-time markets may be inappropriate. To assure efficiency and reliability, the central authority must plan and manage transmission.

1. Introduction

Existing wholesale markets for electricity in the United States vary widely in terms of their emphasis on short-run operational features and the exchange of energy. Some jurisdictions also employ a market-driven selection of suppliers to maintain both system reliability and service quality through selection of operating reserves and regulation. But none of the short-term markets determine the provision of VARs to support system voltage. Given the prominent role that VAR shortages played in the sequence of events that led to the August 14, 2003 Northeast blackout, the U.S. Federal Energy Regulatory Commission (FERC) has expressed an interest in determining whether or not and how the introduction of VAR markets might enhance the system's reliability and efficiency.

This analysis addresses that issue, but in the much broader context of determining an optimal bulk power supply system, both in terms of such a system's operation and of its investments for capacity in transmission lines, generation, and capacitors. This broad, integrated perspective is required because of the complex interactions between individual aspects of the electricity supply system. By using the economic objective of maximizing net benefits to society (gains from consumption of electricity that is reliably provided at stable voltages minus the cost of efficient provision), we not only determine optimal levels of energy consumption and installed capacity of facilities but also estimate the socially optimal level of reliability endogenously by weighing its benefits and costs. By adopting the perspective of a benevolent social planner, the analysis identifies the decisions that can be decentralized and determined efficiently through markets and the services that, because they have public-good-like attributes, require some intervention by a central authority to properly provide that aspect of the electric power supply.

In earlier analyses it has been demonstrated why the reliability (see Joskow and Schmalensee, 1983, and Kleindorfer and Fernando, 1993) and quality including voltage, stability, and frequency (Toomey et al., 2005) of electricity that is served from a wired network has public-good aspects. In economics terminology, the market failure that arises is not because of the lack of competitive supply of those quality-related components. Rather, the problem arises because all customers in a neighborhood who are served from the same wires receive an identical level of those quality-of-service attributes regardless of individuals' possibly widely different valuation of those services. Thus, the market failure is in the demand side since individual customers have strong incentives to understate or overstate their preferences for reliability. Regardless of what they claim they are willing to pay, each of them receives an identical quality of service. So if a buyer perceives that their actual bill will be related to their stated preference, then they have an incentive to understate the value of reliability to them in anticipation that others will vote for and pay for it. Of course, a similar incentive exists for all other customers to "free ride" and the net effect for this market is like the "tragedy of the commons" with too little reliability provided through the grid. While individual customers can respond to this market-based system by installing their own emergency standby generation, if that outcome is the efficient, least-cost solution, the electricity grid probably should be abandoned. If it is not, some regulatory authority is required to establish and enforce cost-effective reliability, voltage, and frequency for the grid, all of which are public goods.

The reason that some central authority is required to operate the grid is that public goods are nonexcludable and nonrival and cannot readily be supplied by decentralized markets. Private

goods are excludable and rival and can be efficiently supplied by markets . Excludable means that consumers can be kept from enjoying a good either by sellers or by a consumer who owns a good and an individual consumer chooses whether to buy the good and how much of it to buy. Rival means that a good that is consumed by one person cannot be consumed by another. A simple example of a private good is an apple. If you buy one, no one else can take that apple away from you (legally anyway), so it is an excludable good. Similarly, if you eat (consume) it, it is gone and no one else can enjoy eating it, so it is a rival good. As a result of these characteristics, private firms can produce and have appropriate incentives to supply such private goods to customers. In contrast, consider a public good such as a street sign. A street sign placed on a residential street corner can be seen by all who pass by. It is not excludable (or it would lose its purpose). Similarly, a driver of a passing car who needs information provided by the sign can obtain the information from it without in any way diminishing the ability of a second driver to obtain information from the sign. The sign is not rival. These properties make provision of public goods by private firms difficult or impossible. For example, imagine that a city decided to “deregulate” street signs. You, as an entrepreneur, decide to get into the business of providing street-sign services. After renting space for your sign from the owner of a corner lot, you attempt to collect fees from passing motorists. Imagine asking a driver who just took a good long look at your sign for the usage fee. Surely the driver will say “Oh no, I wasn’t looking at the sign. I just wanted to take a good look at you.” This behavior is called free-riding because users can get the information, avoid the fee, and hope that enough other “fools” will contribute to keep the sign in place. The result of free-riding is an underprovision of public goods, and it is a problem created by the behavior of consumers of the service.

Unlike purely private goods, where the consumer chooses the amount to be consumed by his or her household, with public goods, to insure adequate provision, some central authority or the actions of many determine the level of provision. Thus, individual consumers decide how much real and reactive power to consume by turning air conditioning, lights, computers, and televisions off or on. Individual industrial customers also control use of motors, computers, and other power-consuming devices. So, real power and reactive power are private goods even though additional amounts are needed as inputs to maintain system voltage and reliability (Hogan 1992b). Private goods are typically used in the production of public goods. The metal post, steel or aluminum sign, and paint needed to make a street sign are all private goods needed to make a public street sign. In fact, reactive power, which is a private good necessary to produce the public goods of voltage and reliability, is sometimes mistakenly described as a public good because it is needed in the production of these public goods. Note that when voltage, a public good, drops in an area, an independent system operator (ISO) or other centralized operator must decide whether to obtain reactive power to restore voltage, a public good. Toomey et al. (2005) provides an engineering and economic model that incorporates the true economic value of reliability and voltage along with appropriate engineering constraints. The model allows for sorting out of the nature of the relevant commodities. The nature of these commodities has implications for the types of markets, if any, that can successfully provide reliable high-quality electric power.

The Northeast power outage of August 14, 2003 provides a dramatic illustration of the lack of attention these public-good aspects have received in restructuring the electric industry. The voltage of a system must be maintained near the design level or customer equipment will be damaged. Reactive power is necessary both to maintain voltage and to support the flow of real

power on transmission lines. It was reported that at times prior to the final cascade to a blackout that the voltage level fell on certain system busses. This is a clear indication to operators of a problem and needs to be immediately addressed. When the operator requested that some generators reduce their output of real power and increase their output of reactive power (for which they would receive no compensation under the market design then in place), the generators procrastinated because they were making so much money selling real power. However, while the benefits to the network of complying with the operator's request could have easily compensated for the individual generators' income losses, no mechanism was in place to transfer adequate benefits to the individual generators.

When load (i.e., customers) is cut off from the system for the protection of customers, it is often because the large loads have caused the voltage to become depressed beyond an acceptable limit. As load is removed, the production of real power will exceed demand and the system frequency will rise to adjust to the mismatch. That is, unless the generators are ramped back quickly, the excess production of real power will cause generators to spin faster as excess energy is absorbed by the rotating mass contained in the turbines. As a consequence, the system's frequency will rise faster than the Automatic Generation Control (AGC) system can adjust to. Sizable deviations from the design frequency for a generator can cause extremely expensive damage to these machines, (e.g., damage to the turbine blades). In response to deviations in frequency and the resulting large power swings that occurred during the cascade phase of the blackout, automatic protection systems tripped generators offline to avoid such damage and generators tripping offline contributed to the collapse of the rest of the system.

All of these factors—the decision by generator owners to argue with operators about the need for them to supply reactive power to help maintain voltage, the automatic decisions to cut off customers when voltage deviates beyond limits, and the automatic decisions to shut down generators when frequency deviates too far from the design specifications—illustrate the problems associated with the provision of public goods. Current system designs are conservative and favor protecting equipment by removing it so it is not damaged and available for use after the emergency has passed.

This analysis delves in some detail into the constituent electrical components that together provide reliable, high-quality service over a network. The three constituents of service desired by buyers are the flow of energy, its quality (as much as they want at the flick of a switch and at a specified voltage and frequency), and its reliability (few unannounced interruptions of service—as opposed to “interruptible” service where outages are preceded by a warning that allows buyers to take action). Some user equipment such as motors, welders, and induction heaters require VARs in addition to energy to operate effectively, and that demand for VARs is a function of a private good and can be arranged through a market. In all electricity systems, these demanded services are provided through combinations of energy and VAR supplies from generation, by providing redundant generation (with the right combination of ramp rates) and transmission facilities, and by installing capacitors. But the demanded services and attributes do not have a direct one-to-one correspondence with the supplied services that satisfy them. So one role of the system operator and planner is to maintain a balanced translation between desired attributes and the supplied constituent components of service—a real-time assembly problem. The planner also must ensure the availability of adequate excess capacity for each constituent to maintain optimal levels of reliability in the face of likely failures and contingencies.

Thus, in addition to the theoretical analysis, a simple, stylized model of an electrical network is presented to simulate the implications of the analytic results. Sensitivity analyses are performed to demonstrate the robustness of outcomes. In addition, the results of related experiments in which people attempt to profit by selling both energy and VARs to a simple electricity network (the PowerWeb 30-bus model) provide insight into the effectiveness of market structures. Finally, the adequacy of market-related allocation mechanisms is reviewed in light of the numerical and experimental results.

The next section describes an optimal economic model of voltage and real and reactive power in a network environment with the possibility of generator and line failure. The implications of this model for market design are explored through simulations of optimal economic performance. Section 3 provides examples of market power arising from reactive-power issues. Section 4 presents recommendations for efficient market design.

2. Conceptual Basis for Evaluating Market Structures for Reactive Power, Voltage, and Reliability

In this section we attempt to describe what some of the characteristics of an ideal electric power system should look like in terms of structure and performance. This “first best” system is obviously not achievable in the short run, but it serves to identify the appropriate target, in terms of market design and operation. We hereafter show that a real world “second best” system, if it is ever to approach a first best, must have markets for reactive power (hereafter designated as VARs). However, we also show in simulations that these markets are likely to have some peculiar characteristics. The goal of the ideal system would be to maximize the expected net benefits over all the possible states of the system. That is, the ideal system would maximize the sum of benefits minus costs in each state of the system multiplied by the probability of that state occurring. We consider two types of failure that can produce different states of the system. First, generators can fail; second, lines between nodes can fail. We take these probabilities as given in this simple analysis of potential reactive-power markets, but obviously they are functions of expenditures on maintaining the system.

2.1 The Network

The simple network used in our analysis and shown in Figure 1 is structured to allow a clear graphical presentation of the results of the simulations. The spatial configuration of the network, particularly the location of generation, is not optimized and is assumed to be constrained by other factors (e.g., location of fuel supplies). Thus, the numerical results are illustrative of this particular network and might vary with a different spatial configuration. However, the qualitative results, such as which services are public and which are private, are general. Each bus in this sequence of busses has a load, and three generators are located at the first bus. The busses represent substations, and it is assumed that the distance between any two sequential busses is five miles. The busses are connected by two identical parallel lines; if there is failure in one line, power can still be delivered via the other. We treat this network as a true alternating-current (AC) system with Kirchoff’s laws holding for all power flows. Correspondingly, the voltage and the phase angle of each bus are solved when determining power flows. The network in our simulations is constructed by optimizing the admittance of the power lines, the quantity of switchable VAR compensation devices installed at each bus, and the size of each of the

generators. The system is operated with the controllable VAR compensation optimally switched in or out depending on the system failure state.

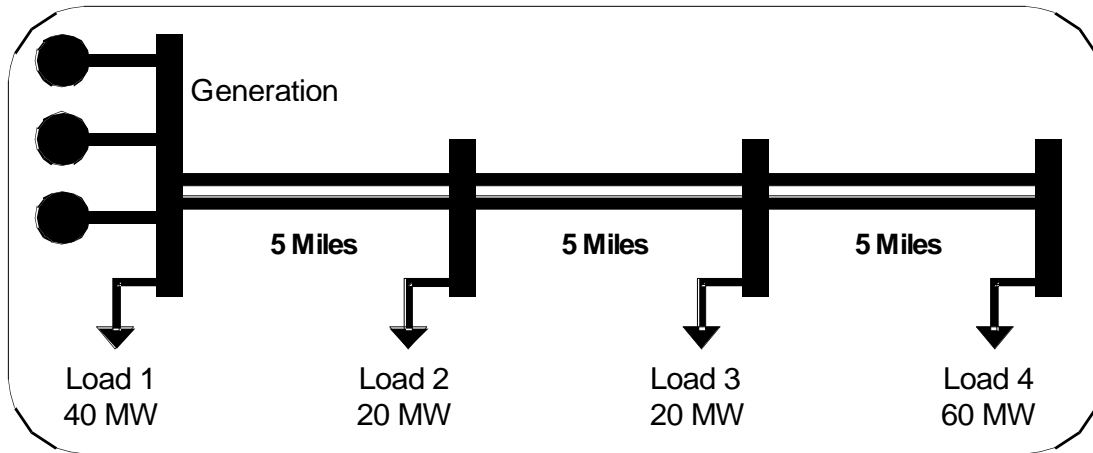

Figure 1

The situation described here may be thought of as a long island. There are generators at one end of the island and a transmission network that delivers power up the island to different communities. There is no way to import power to the island and, hence, the island’s residents must develop their own entirely self-contained electric power system.

2.2 Buyer Characteristics

In a given state, the net benefit to buyers is equal to their maximum willingness-to-pay for real and reactive power minus any damages from deviations in voltage. Figure 2 shows a typical one-hour aggregate demand curve for buyers at a substation.¹ This amount of load is similar to average consumption by 40,000 typical U.S. homes, though the shape of the curve is based on a mix of residential, commercial, and industrial customers. In this figure and throughout this paper, we assume for simplicity that real and reactive power are jointly consumed by buyers in fixed proportions, that each buyer’s power factor is a constant 15% (so the MVAR consumption rate = $0.1517 \times$ the megawatt (MW) consumption rate for all customers at all times).

The demand curve used here and shown in Figure 2 is based on a study done by Woo et al. (1991) that is described in Woo and Pupp (1992). This distribution is bell-shaped and the demand curve, obtained as the cumulative distribution, has the stepped appearance. Thus, while demand is extremely inelastic for typical delivered prices of around \$100 per megawatt-hour (MWh), it becomes much more elastic above \$9,000 per MWh because at that rate many users would prefer to shut down when given the opportunity. Other studies that support this approximate short-run demand curve include Caves et al. (1990) Doane et al. (1988a, 1988b) Goett et al (1988). Hartman et al. (1991), Moeltner and Layton (2002), Sullivan et al. (1996), and Wacker et al. (1985).

¹ As is customary in economics, the independent variable, price, is on the vertical axis.

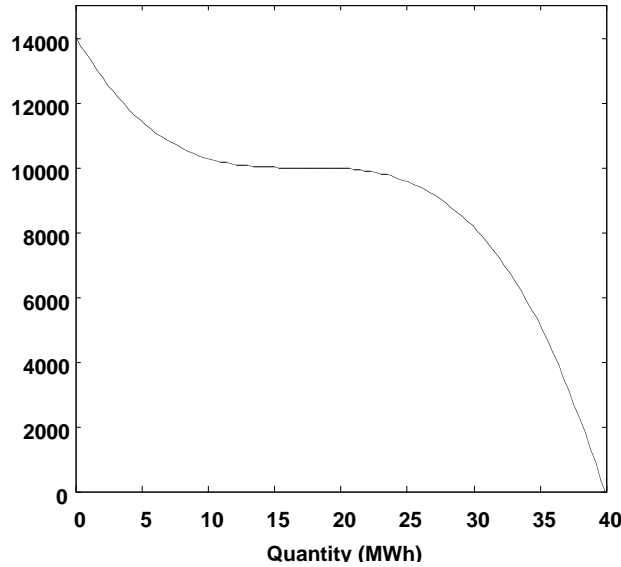

Figure 2. Buyer Demand for Real and Reactive Power

The hourly demand curve shows that the value to customers is vastly greater than the typical cost. If one were to draw a horizontal line in this figure at a typical customer price of \$100, consumption would be very close to the horizontal intercept of 40 MW of real power and 6.068 MVAR of reactive power. However, the majority of customers value electricity so highly that they would not eliminate its use until the price reaches \$10,000 or more. The price for combined real and reactive power at which a buyer will curtail use is called the maximum willingness-to-pay and is the measure of the benefit of electricity to that customer.

As an example of the value of maintaining reliability, consider the difference between two scenarios. In the first, the system collapses completely, preventing all electricity delivery. In the second, the system is still able to serve the 50% of load that has the highest willingness-to-pay. In the demand curve shown here, the value of serving this 50% of load is the area under the left half of the demand curve. This value is greater than $\$10,000 \times 20 = \$200,000$ per hour. However, the revenue obtained from preserving the system and selling electricity at a regulated rate of \$100 (per 1 MWh + 0.1517 megavolt hours (MVh)) is only \$2,000, which is two orders of magnitude less. Clearly, if an investment of \$100,000 (e.g., for tree trimming) would prevent a complete loss of power for one hour and instead allow the system to continue serving the 50% of load with the highest willingness-to-pay, that investment should be undertaken. However, a utility's revenue increase from such an investment would typically be only \$2,000, so a profit-maximizing or rate-minimizing utility would choose not to make the investment in spite of its high value to society. For comparison, a profit-maximizing discriminating monopoly supplier charging unregulated, real-time rates to all of its customers would charge \$200,000 for the added sales that the investment would enable, making the investment worthwhile to such a supplier.

What is the separate value of reactive power in this example? With a fixed power factor of 0.15, a one-MVAR reduction in supply of reactive power would force a one-MVAR reduction in reactive-power demand and a 6.6-MW reduction in real-power demand, jointly valued at approximately $\$10,000 \times 6.6 = \$66,000$ per hour. Thus, a one-MVAR shortage of reactive power (assuming real power is available) could cause a loss in benefits of \$66,000 per hour. In contrast,

switchable capacitors can produce reactive power for a per-period capital cost of approximately \$0.015 per MVAR per hour (based on a capital cost of \$4,100 per MVAR). As this illustrates, the paradox of extremely high value and low production cost is even more extreme for reactive power than for real power.

Value-maximizing buyers would purchase capacitors to reduce reactive-power charges if the charges for reactive power were not bundled with charges for real power as previously described. In our simulations, we assume that buyers have a fixed power factor but can purchase capacitors to reduce their reactive-power demand below that implied in Figure 2.

We further allow the installation of inductors, which consume VARs when switched in. While shunt inductor compensation is something that is not done routinely today, it is needed here as an option in designing the optimal transmission system. In some instances, large flows of VARs are required to satisfy power-flow equations or else power delivery must be curtailed. For a node to be able to sometimes receive more VARs than customers and generators there can consume, inductors are needed to consume the extra VARs. The assumed per-period capital cost of this type of inductor is \$0.06 per MVAR per hour (C. W. Taylor, 1994).

The final component in modeling electricity buyers is the potential damage caused by voltage deviations. The following figure shows aggregate damages for buyers with the aggregate demand curve shown in the preceding figure. This damage function is a very rough approximation based on “a good guess” and no more. The reason, from the perspective of economics, to incorporate such a damage function rather than relying on arbitrary nodal limits on voltage is that this allows us to show that voltage is, in fact, a public good. Unfortunately, confusion exists in this regard in part because of engineering work done by Kim (2005) that argued for a market for voltage. We show that this notion is incorrect because individual customers do not have the power to choose the level of voltage they receive from a node. So voltage is not a private good. As shown in the introduction, in the case of private goods, buyers must have the power to choose whether to consume a good and at what level to consume it based on price alone. Voltage at a node in a network, on the other hand, is determined by the interaction of all of the decision-makers in the system (see the Appendix for a technical demonstration) and must be regulated by some authority (e.g., an ISO) or excess damages will result. In contrast, customers can decide how much real and reactive power to consume. The damages shown will naturally help to define appropriate voltage levels at the nodes in the system as part of the maximization of expected net benefits over the ideal system as a whole.

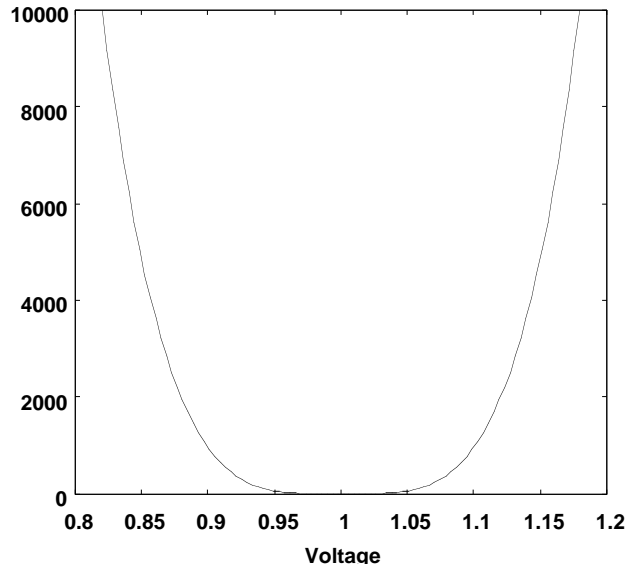

Figure 3. Aggregate Equipment and Appliance Damages from Extreme Voltage

The equation for net benefits to customers from electricity service can be written as

$$\text{customer net benefits} = \text{willingness-to-pay for real and reactive power} - \text{costs of capacitors} - \text{voltage damages.}$$

2.3 Generator Characteristics

Generators are assumed to have capability curves as shown in Figure 4 with upper and lower limits for real-power production, G , and the capability of producing reactive power, Q , also with upper and lower limits. This curve is an approximation of the usual capability curve derived from a generator's rating and its field and armature heating limits (ref: C.W. Taylor). While it is important to include the generator capability relationship in the analysis, the stylized shape we use does not limit the general conclusions of the analysis. The model assumes that fuel costs depend on real-power production but not on reactive-power production. However, as Figure 4 shows, a generator's maximum production or consumption of reactive power increases as its real-power production is reduced below the maximum level.

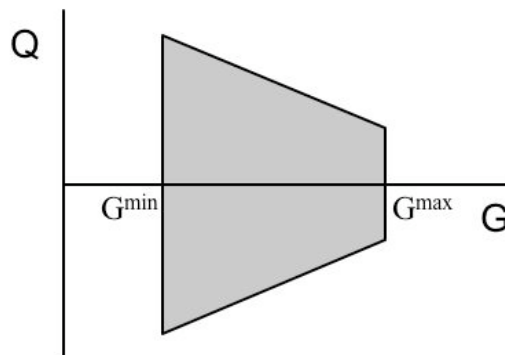

Figure 4. Generator Capability Curve

2.4 Theoretical Results

The risks faced in this system are failures of any, some, or all of the three generators and failures of any, some, or all of the six line segments. Each possible state of the system has a known probability. A “state” in economics refers to a particular combination of possible occurrences, such as, for example, one generator down and all lines up with high load; all generators up, one particular line down, and low load; or all generators and lines up. The Kuhn-Tucker conditions shown in Appendix A must be satisfied by truly efficient markets and operations and the Lagrange multipliers in the problem, when divided by the probability of the relevant state, can be interpreted as real-time optimal prices in that state. We now provide an economic interpretation for the key optimizing conditions and describe their implications for market design.

Equation 9 in Appendix A can be interpreted as a description of optimal buyer behavior for purchase of real power and implies that

Demand price = nodal real-power price + power factor × nodal reactive-power price.

Thus, ideally, buyers should pay the nodal price for real power consumed plus the nodal price for any reactive power consumed.

Equations 10 through 12 in Appendix A describe optimal generator behavior and imply that, at a generation node,

Nodal price of real power = marginal cost of producing real power + nodal price of reactive power × any marginal loss in reactive power to produce real power.

Thus, to provide the correct incentives, generators should receive nodal prices for both real and reactive power produced.

Clearly, from these conditions, real power and reactive power are private goods for both buyers and generators since nodal prices convey the correct incentives.

Equations 13 through 13'' optimize nodal voltages. The general case is shown in 13' and can be interpreted as

Marginal benefits to transmission of increased voltage for all lines connecting a node + marginal benefits of increased reactive-power production by inductors and capacitors from increased voltage = marginal damages from higher voltage + net costs of marginal changes in reactive power consumed to increase voltage.

Since, by definition, more than one line is connected to a node, benefits of higher voltage for transmission flow are summed over multiple lines, the key condition for a public good. Also, benefits to transmission at a node are increased by higher voltages at adjacent nodes. Thus, free-riding on the voltage from neighboring nodes is possible. Similarly, higher voltage at a node benefits reactive-power production from capacitors and inductors at the node. In addition, marginal damages from voltage deviation accrue to all buyers connected to a substation so these are implicitly summed in the damage function as well. Thus, voltage at a node is a social decision that directly affects benefits and costs to many participants and must be jointly determined in the public interest—that is, voltage is a public good. In contrast, the private-good

conditions for real and reactive power only involve the respective prices and benefits and costs to the particular buyer or seller.

Equation 14 in Appendix A optimizes line angle and also takes the form of a public-good condition that balances benefits of increased transmission against increased costs for reactive power and the constraint on line angle reflecting stability requirements, etc.

Equations 15 and 16 optimize investment in capacitors and inductors, respectively, at each node. Such investments may be undertaken, as appropriate, by private investors, line operators, and customers. Assuming that voltage is close to one, the conditions approximately set the contingent-claim prices summed over states for reactive power at the node equal to the marginal cost of investment at the node. Or, using real-time prices (contingent-claim prices divided by the state probability), the conditions set the marginal cost of investment equal to the sum across states of the probability-weighted real-time prices for positive or negative reactive power at the node. Thus, optimal contingent-claim, or real-time, prices provide the correct investment signals for capacitors and inductors.

Equation 17 plus equations 10, 11, and 12 and the simulation results hereafter presented suggest that optimal investment in each of the three power plants is determined by the expected profits that are obtained solely from the state in which the particular generator is the only one running (the other two have failed). Thus, the marginal cost of investment in generation is set equal to the increase in expected revenue obtained in states in which that generator is the only one running. The simulation results show substantial excess capacity, so optimal investment is concerned only with the very high prices and profits that occur in the state where the single generator constrains total capacity.

Equation 18 sets the marginal cost of investing in line capacity equal to the incremental transmission revenue for real and reactive power obtained from the capacity increment across all line segments net of the cost of reactive power consumed to maintain voltage. Note that the transmission charge for real or reactive power across a line segment is the nodal price difference for real or reactive power, respectively. We show in the simulation that, with optimal investment in lines, the thermal line limits never bind and transmission fees are near zero except in the case of line failures. Thus, transmission revenue is primarily generated when line failures occur in the simulated system. Note that if a direct-current (DC) optimal power flow were utilized, transmission fees would always be zero with the truly optimal level of investment in lines. Using the optimal DC power flow would reduce “seemingly optimal” investment in line capacity until thermal limits became binding. Note that the simulation excludes line losses which are small.

2.5 Simulation Results

Each generator is assumed to have a 4% probability of failure and the odds of failure for each line segment are one out of two thousand. Given these probabilities, some states are highly unlikely, such as two line segments failing at the same time. To keep the analysis manageable, these highly unlikely states are not considered. In addition there are six possible network states in the simulation: the base state (no failures), failure of one of the generators, failure of two of the generators, failure of one of the line segments between busses one and two, failure of one of the line segments between busses two and three, and failure of one of the line segments between busses three and four.

The simulation further includes peak and nonpeak demand. Peak demand as shown in Figure 1 is 50% higher than nonpeak demand. Each level of demand occurs half of the time. Given, then, the two demand levels and six possible network states, there are twelve different states for the system. For maximizing net benefits across all of the states, we solve the simulation to find the optimal system construction, which is illustrated by the following table, and determine how the system will optimally be run in each state, which is described by the diagrams in Figures 5 through 10.

Table 1. Optimal System Construction

Size of Each Generator (MW of capacity)	85.8
Size of the Lines (Per-unit admittance)	4.5
Capacitors at Bus 1 (MVAr of capacity)	0.6
Capacitors at Bus 2 (MVAr of capacity)	45.3
Capacitors at Bus 3 (MVAr of capacity)	24.6
Capacitors at Bus 4 (MVAr of capacity)	8.4
Inductors at Bus 1 (MVAr of capacity)	0.0
Inductors at Bus 2 (MVAr of capacity)	0.0
Inductors at Bus 3 (MVAr of capacity)	0.0
Inductors at Bus 4 (MVAr of capacity)	9.6

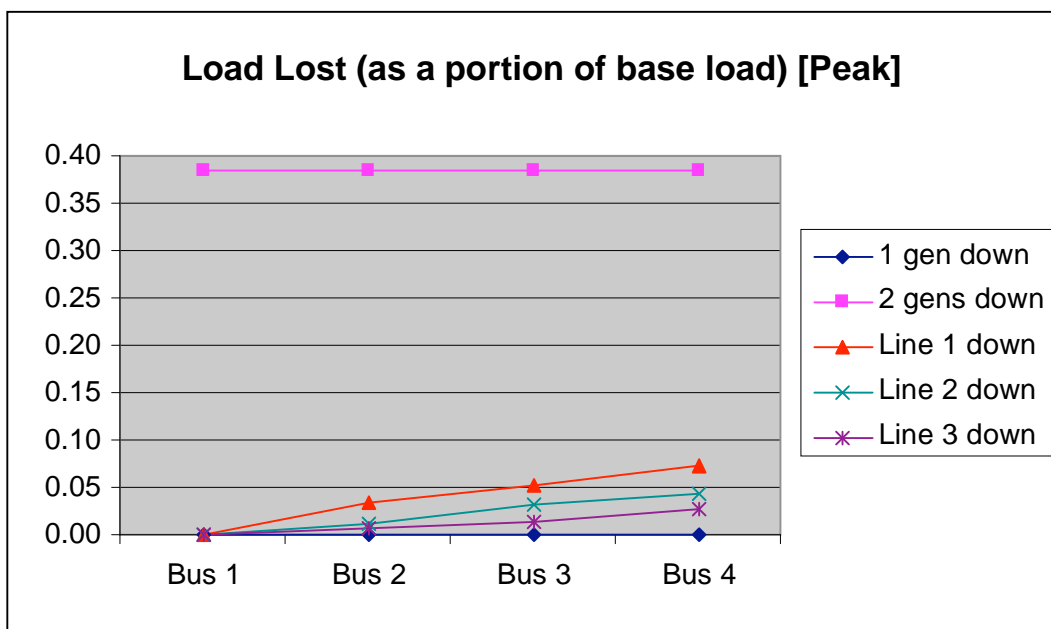
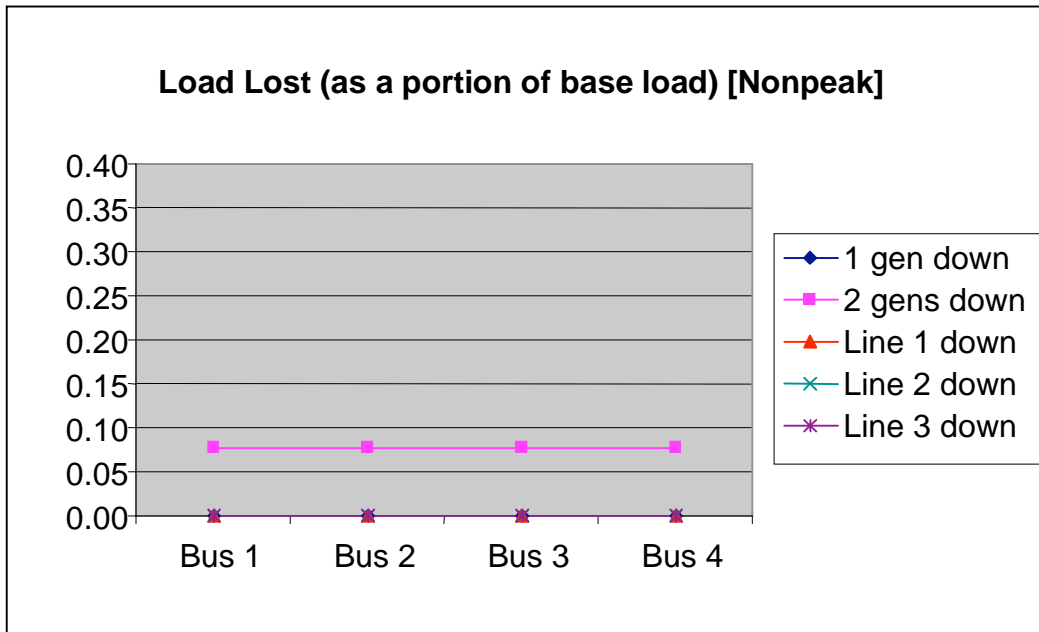

Figure 5

In the peak states, enough generation is optimally constructed so that the failure of one generator results in no drop in load. Interestingly, this is consistent with standard system design practices. When two generators fail, however, significant load must be dropped because a single generator is not capable of producing the entire peak demand. When there are line failures, the loads at busses two, three, and four drop because transmission becomes more costly. It becomes more costly not just in the line where the failure occurs but in the other lines as well, as will be explained shortly. Because transmission is then more costly, it is optimal to transmit less, yielding the load reductions shown here. The losses in these loads are greater when the failure

occurs in an earlier line. This is because transmission is larger earlier in the lines and getting more transmission over the single line that remains after a failure results in higher costs that then make less transmission optimal. In nonpeak states, there is loss of load only when two generators fail and the loss is much smaller than in the corresponding peak state.

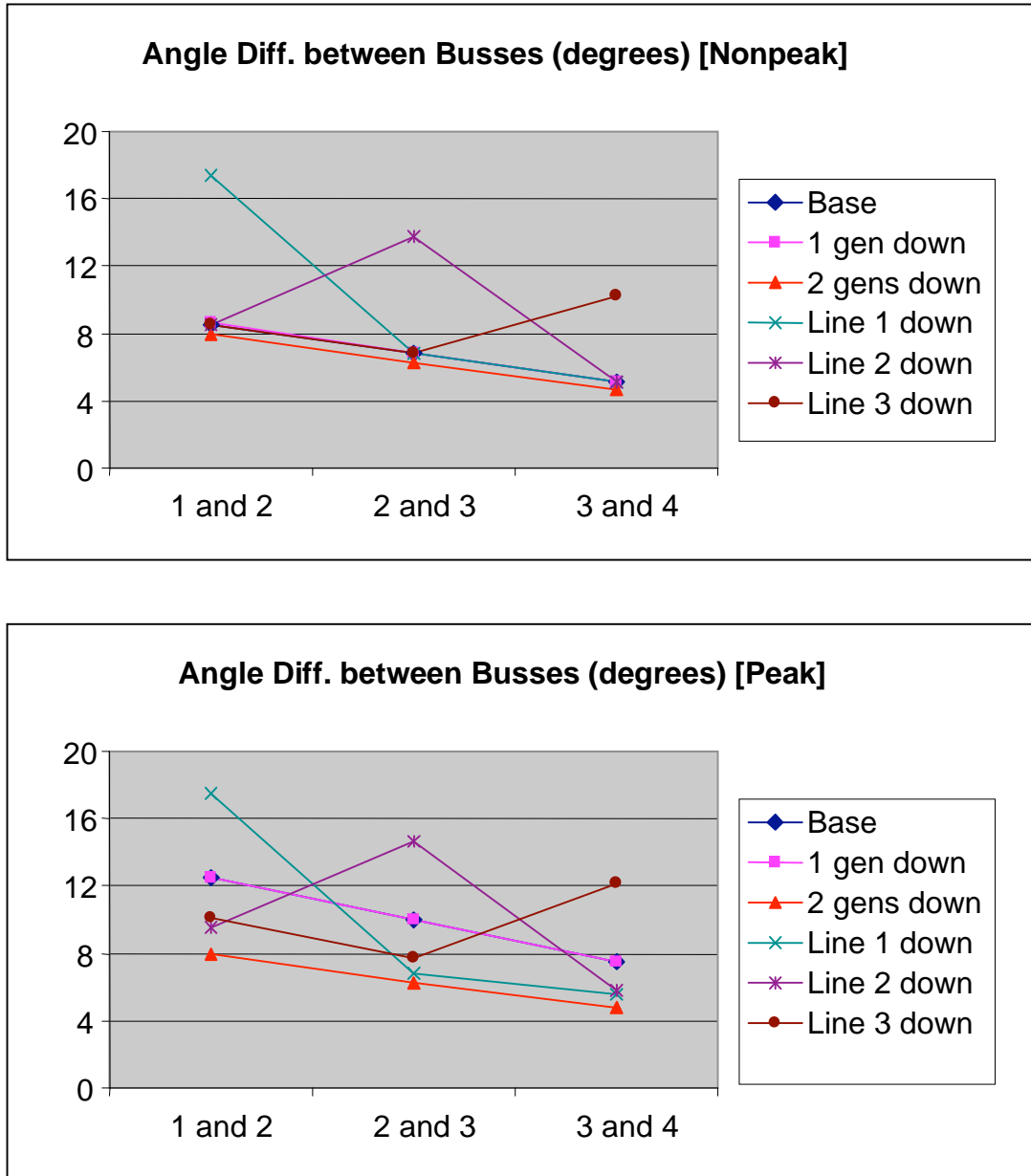

Figure 6

Real-power flow between two busses is driven primarily by the difference in the phase angle between the two busses and by the size of the line. When there are no line failures, the angle difference gets smaller moving down the line as the amount of power transmitted declines. When a line segment fails, the angle difference over that line segment must be considerably higher to

restore flow since the size of the line between those busses is now halved. This increased angle difference over the failed line segment can result in difficulties for transmission over the other two line segments, as we will explain.

For the stability of the system, the total angle difference for the entire length of the line in the model is limited to 30 degrees. If restoring transmission over a failed line segment uses an angle difference of 18 degrees, for example, that leaves only 12 degrees for transmission over the other four segments, resulting in transmission difficulties. These difficulties are a fundamental cause for load drops at busses located prior to a line failure (along with loads at busses after it) when that failure occurs in the peak state. In the diagram shown in Figure 6, note that, in peak line-failure states, the angle differences in the nonfailed lines do drop below their base-state levels. In the nonpeak states, with lower flows, smaller angle differences can be used for transmission. There is not, in fact, an instance in the nonpeak states in which the total angle difference reaches 30 degrees, which explains why load never drops in nonpeak line-failure states. Note also that, in states in which two generators fail, the angle differences all drop simply because less real power is transmitted.

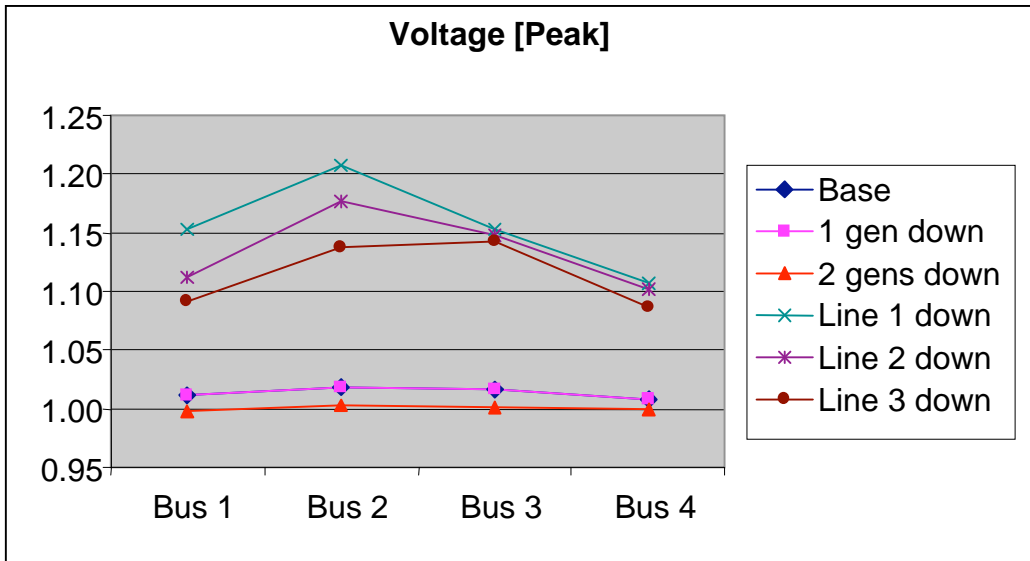
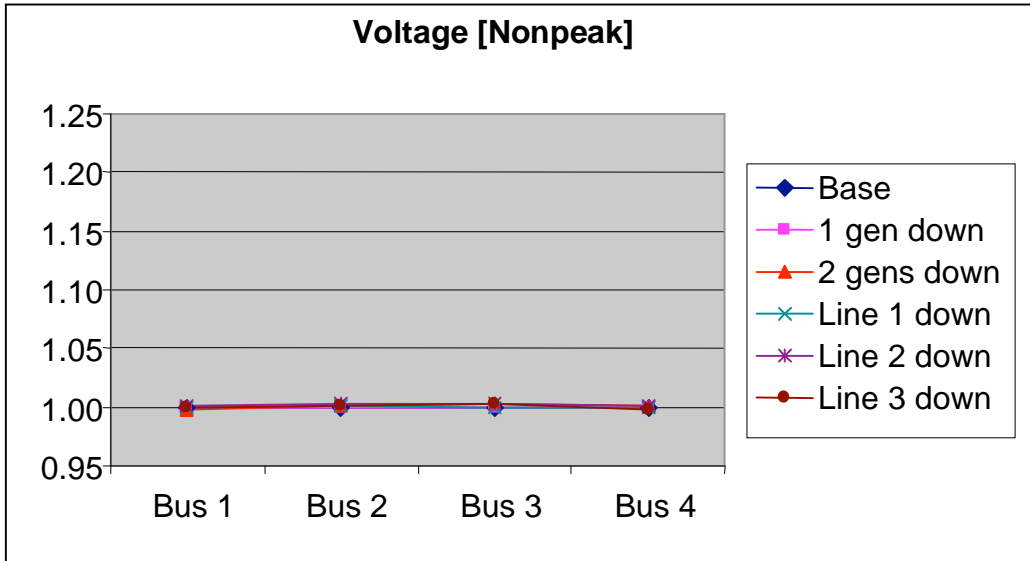

Figure 7

The third factor in real-power flow is voltage. Higher voltage at either end of a line segment increases the available flow through that segment. Hence, when there are difficulties with transmission, it will generally be optimal to increase the voltage even though this will result in some voltage damage. Because of the damage that occurs from increasing available transmission in this way, this method of increasing flow capacity is costly. Note that, when there are no difficulties with transmission, the voltage at all the busses remains essentially at one, yielding zero damage. When there has been a line failure and there is peak demand, there are difficulties with transmission over all lines as previously explained and optimal voltage at all busses is greater to help flow in all lines. Given this costly transmission, the choice is between smaller losses of load with greater damage or larger losses of load with less damage. The optimal decisions for this simulation are illustrated in Figure 7.

Note the simulation includes building optimal lines. And, in fact, building a larger line can eliminate transmission difficulties even with segment failures, which would then prevent voltage damage. However, there are costs associated with building larger lines and the probability of facing the high voltages is low. Optimal line size is determined based on the costs of its construction, the probability of line failures, and the outcome of lost load or voltage damage when failures occur. The optimal line allows all real power to be delivered during nonpeak demand and when there are no line failures, nearly all real power to be delivered when there are failures with peak demand, and some voltage damage in the peak-load line-failure states.

As shown in Figure 8, high prices for real power optimally occur in certain failure states because high prices are required to get buyers to reduce consumption. When larger reductions in load are necessary, optimal prices are higher still to convince buyers to make larger reductions. In the peak base state, the peak one-generator-failure state, and all but one of the nonpeak states, the price that buyers pay is simply the marginal cost of production and basic delivery. For customers with real-time metering, real-time prices can provide for optimal curtailment of consumption, as these customers have an incentive to turn off electricity uses that are not worth their expense in times of high prices. For customers without real-time meters, real-time prices are not an option, but reliability-differentiated service could be used to implement a contingent-claim market such that buyers would pay an expected price for the real power that they use. Those who choose to pay a higher price that reflects the high prices of certain failure states would be able to continue consuming in those states. Those who choose to pay a low price would be shut off in those states.

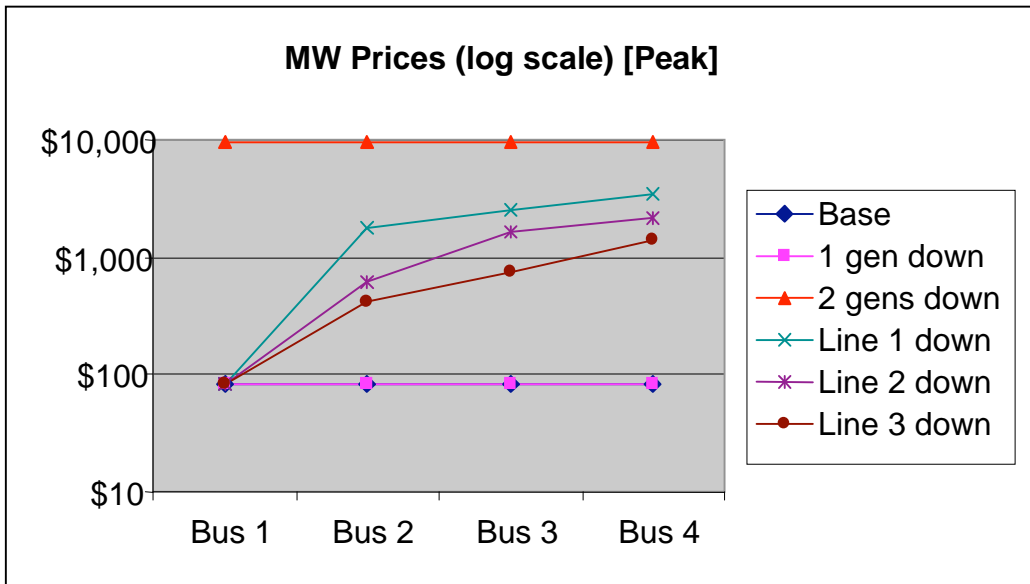
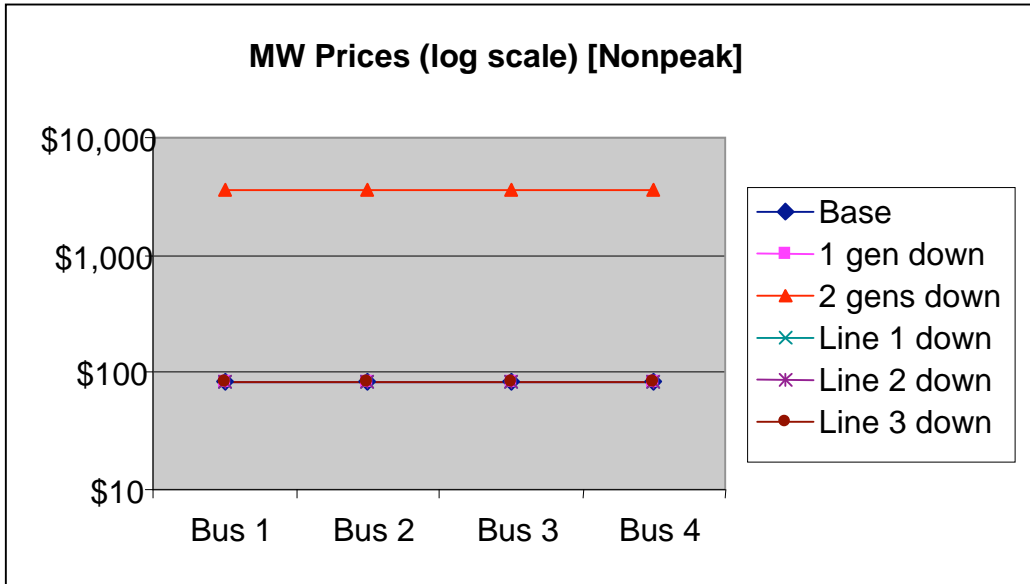

Figure 8

Reactive power is required by buyers for real-power consumption and required by lines in order to satisfy Kirchoff's laws for transmission. The capacitors installed at the busses provide reactive power when they are switched in. Sometimes transmission requirements for reactive power can result in too much reactive power at a bus. Inductors at such a bus can be switched in to consume those extra VARs. At the first bus, reactive power can be both produced and consumed by the generators. As a result, in this simulation, there is essentially no need to install either capacitors or inductors at that bus. Figure 9 shows the VARs that are produced/consumed by capacitors/inductors. Negative values indicate VAR consumption. Note that the quantities of capacitors and inductors that are installed are just adequate to provide the maximums shown in the diagram.

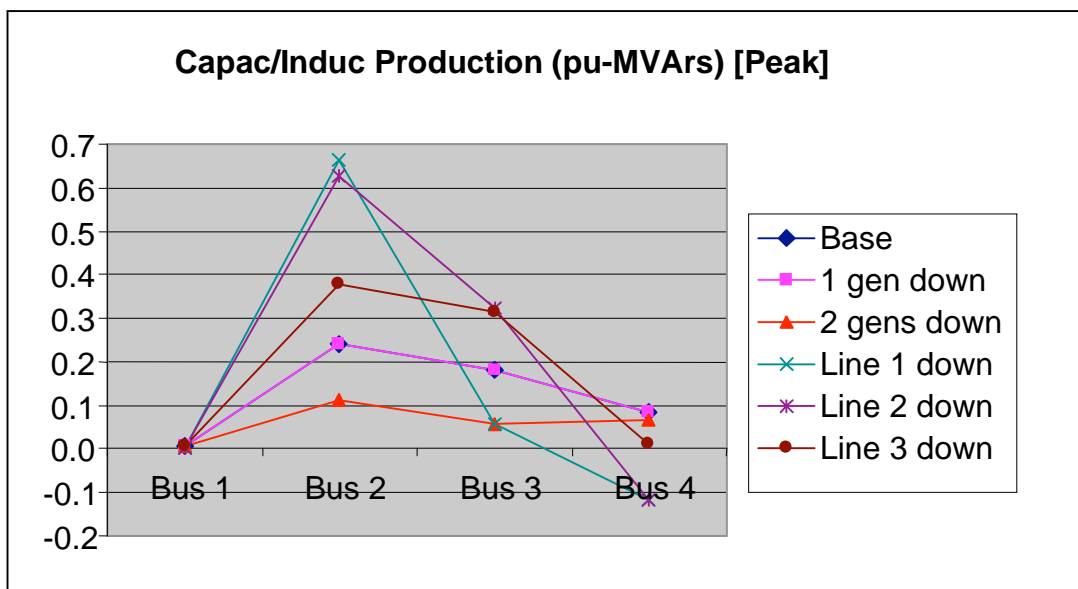
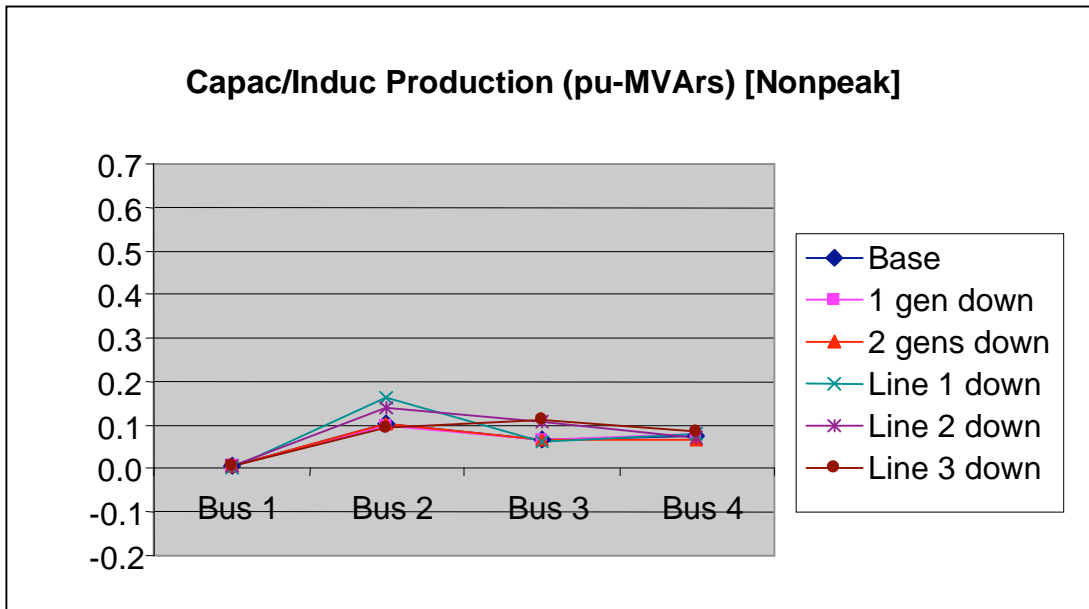

Figure 9

In the peak two-generator-failure state, VAR production falls from its base-state level because there is less demand by both consumers and the lines. When a line segment fails, extra VARs are required by the line segment that remains, and there is additional VAR production to meet this requirement. To satisfy Kirchoff's laws while meeting this requirement, additional VARs are required to flow away from the failure as well, through the other lines. This results in large quantities of reactive power at the end busses in these states. At bus 1, the generators can consume the extra VARs themselves, but at bus 4 inductors are required to consume the extra VARs.

As shown in the following figures, most of the time the price of reactive power is zero. At the first bus, VARs can be freely produced and consumed by the generators up to their capability curves, which are sufficient for all states. At the second and third busses, large quantities of capacitors are installed to meet requirements in peak line-failure states, and those quantities are more than sufficient for all other states. At the fourth bus, there is a small, positive price for VARs in the peak base state. This state requires more reactive-power production at this bus than any other state does. In the line-failure states, VARs are flowing away from the failures to this bus. Also, inductors are needed at bus 4 in only two states, making prices for VARs negative only in those states.

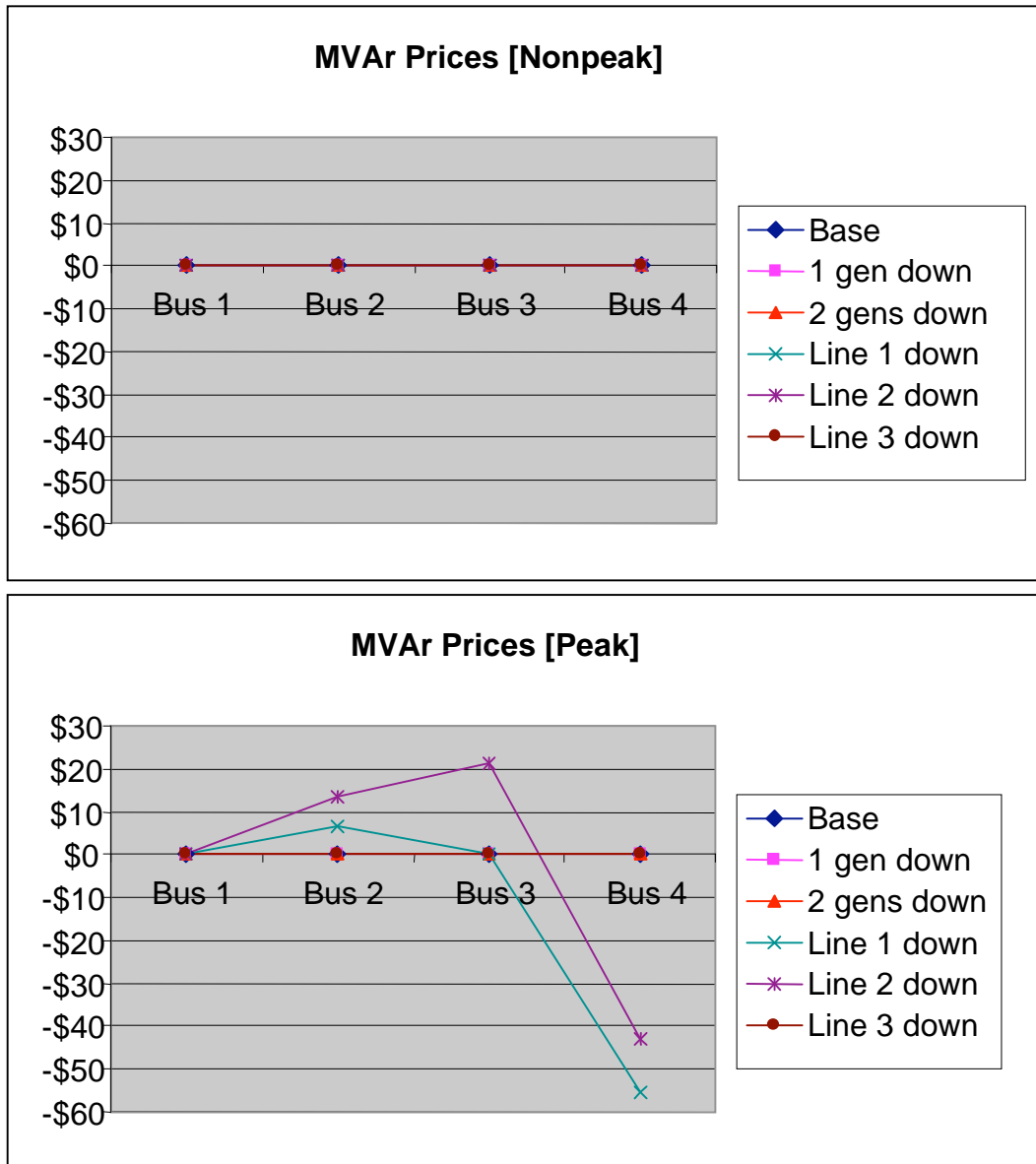

Figure 10

Even when reactive-power prices are zero for the vast majority of the time, the prices charged provide incentives and revenue to pay for the initial installation of both capacitors and inductors because of the relatively high prices generated by particular failure states. Those who installed capacitors and inductors ought to receive that revenue. Furthermore, if the prices of VARs are not regulated and there are not enough capacitors or inductors to satisfy private demand plus the system operator's demand to support reliability and voltage, prices for VARs (positive, negative, or both) are high. This would encourage additional installation, perhaps even by buyers themselves. Additional installation would continue, arguably until the optimal quantity was installed, which would drop prices to optimal levels. Other important results include the large amount of reserves provided in the optimal system as substantial extra generation is constructed to ensure reliability on the isolated "island" used as the example system and the manner in which transmission and voltage interact in failure states.

2.6 Profits

As previously noted, unregulated prices for VARs can provide incentives and revenue for installation of capacitors and inductors. Both the simulation and a theoretical analysis of the model suggest that optimal prices for the system are *revenue-neutral*. That is, they provide just enough revenue to cover installation costs without providing excess profits. This is true not just for installing capacitors and inductors but also for generator construction. It is shown, then, that allowing prices to rise, sometimes dramatically, in contingency states provides strong incentives for installation of capital improvements that will be used in those states and, in fact, the revenue from those prices is necessary to get the optimal quantity of capital improvement installed. Moreover, having that quantity of capital invested provides more than enough capital for all of the other states.

Table 2. Annual Expected Costs and Revenues for Generators, Capacitors, and Inductor

Generators (millions of dollars)		Capacitors (thousands of dollars)	
Revenues from MW sales	\$56	Revenues	\$10
Revenues from MVAR sales	\$0	Annualized installation costs	\$10
Production costs	\$34	Excess Profit	\$0
Annualized construction costs	\$23		
Excess Profit	\$0		
Inductors (thousands of dollars)			
Bus-4 revenues	\$5		
Annualized installation costs	\$5		
Profit	\$0		

With line construction, optimal conditions generate excess profit due to increasing marginal costs in constructing the lines.

Table 3. Annual Expected Costs and Revenues for Lines (hundreds of thousands of dollars)

Line net revenue	\$28
Annualized construction costs	\$14
Profit	\$14

3. Network Constraints and Market Power

The objectives of this section are (1) to illustrate some unusual market situations that appear to be anomalies but are in fact consistent with the unique constraints associated with flows on transmission lines governed by Kirchoff's laws and (2) to explain why the basic characteristics of a market for reactive power are almost certain to lead to speculative behavior by generators. A basic problem for designing an electricity market is that the physical constraints of supplying real power over an AC network may severely limit the number of suppliers that are able to produce energy and ancillary services at certain locations at certain times. In extreme cases, a single

reliability-must-run (RMR) unit may be the only source of reactive power, which is essential for maintaining voltage profiles within specified limits on part of the network. When only a few suppliers compete in a market, the existence of market power is inevitable and the suppliers can, if allowed, increase their profits by speculating. When this type of speculation occurs, prices offered into the market will be higher than true production costs and some production capacity may be withheld. The market is not “incentive compatible” because suppliers can benefit by submitting offers that are substantially higher than “honest” offers that are equal to their true marginal costs.

The complexities that are inherent in an AC network imply that a viable electricity market cannot be designed by blindly applying market institutions that work well for other goods. Most apparent anomalies in electricity markets have surfaced during the course of our research on various aspects of deregulating the electric power industry; they were found, not concocted. These unexpected situations are quite different from the more predictable effects of transportation in a market for the conventional type of commodity considered in economic textbooks.

There is already a large body of research involving market power and the implications of congestion for electric power markets. Rassenti and Smith (1988) performed studies applying experimental economics to radial networks; Hogan (1992a, 2003) studied AC power flow using triangular networks. However, few studies deal with the intricacies of an AC network. Our examples of anomalies typically involve larger, more realistic networks based on IEEE test models, and, as a result, we have evaluated a set of market conditions that is richer than the ones examined by other researchers.

When a realistic network model of an electrical grid underlies the market-clearing mechanism, the optimization, called an *AC Optimal Power Flow* (AC OPF), is a formidable mathematical problem to solve. As a result, a simplified linear model of the grid is very often used in practice for determining market prices. Not that some form of AC analysis is used by engineers to determine flows and voltages, but the actual prices are determined by a DC power flow. This simplified optimization is implemented by, for example, adding ad hoc restrictions (called proxy limits) on real power line flows that put constraints on dispatch to approximate the true conditions governed by Kirchoff’s laws. In general, this type of approximation works reasonably well under normal operating conditions, but it generally fails when the network is stressed or highly congested. The inaccuracy of the approximation used to determine market-clearing prices can increase opportunities for gaming by suppliers adding an extra layer of inefficiency to the market. To avoid this additional source of inefficiency and focus on the effects of the grid alone, in this section the market-clearing mechanism is based on a full AC OPF that incorporates all of the credible contingencies and nonlinearities implied by Kirchoff’s laws.

3.1 The Effects of Reactive-Power Needs on the Market for Real Power

While many proposals exist for how to deal with reactive-power issues, to date none of the deregulated markets has introduced a comprehensive plan for using a market to manage reactive power. Nobody disputes the importance of reactive power, but it has been difficult to arrive at a consensus about the best structure of a reactive-power market. The network requires reactive power simply because it is energized, in order to maintain an adequate voltage profile (without which electricity is useless to consumers), and to give extra degrees of freedom to the system

operator so that the network can be controlled in an efficient manner. Having these extra degrees of freedom allows the system operator to configure the system to achieve the best use of existing transmission capacity. Total cost, system losses, nodal price differentials across congested lines, and operational voltage limits are all assessed in the dispatch produced by an AC OPF. The greater the number of controllable reactive injections into the network, the more freedom the system operator has to optimize dispatch and lower costs. However, the most important sources of reactive power on the network are the generating units, which, by virtue of the unit-commitment decision, can produce reactive power only if a minimum block of real power is dispatched at the same time.

Four examples of increasing complexity are discussed in this section to illustrate how the production of reactive power by generators interacts with the market for real power. The simplest example illustrates the implications of having a generator become a “reliability must run” (RMR) unit at high loads when the unit is essential for voltage support. The final example illustrates how the nodal price of real power can be substantially higher than the highest offer price submitted into a market when production from one generator causes other units to be re-dispatched to maintain an acceptable voltage profile on the network.

1. Reliability-Must-Run Units

The system discussed in this example arose during the design of an experiment using the PowerWeb [See Zimmerman, et. al., 1999] platform to test the performance of different markets for real energy. The underlying topology of the network is based on the IEEE 30-bus system. This network was used to conduct an experiment to compare the economic performance of different clearing mechanisms in determining nodal prices. The market was divided into high-load and low-load periods, and it turned out that, in the high-load period, generator 4 at bus 27 (see Figure 13) was a must-run unit because voltage limits were reached at bus 30. The individual in control of generator 4 quickly learned to offer the initial block of real power at the highest price allowed (i.e., the reservation price). Since the first block from a generator cannot be partially dispatched due to the physical limits of the generator, the block must be wholly accepted or rejected. Although generator 4 was able to sell the initial five MW of power at the reservation price, that price did not set the overall market-clearing price for real power because the unit was constrained to a minimum level of dispatch (i.e., it was dispatched out of merit order). The important implication for market power is that the individual controlling generator 4 did not have to know that this was an RMR unit. The response of the market to higher offer prices at high loads provided enough information for the individual to recognize that generator 4 had market power and to exploit this advantage to earn higher profits.

2. VAR-Related Flexibility of Dispatch

This second example surfaced while testing a unit-commitment algorithm. This algorithm is based on Lagrangian relaxation but permits the inclusion of nonlinear AC OPF constraints. A realistic 168-hour load profile was used to test the algorithm, and the specified generating capacity was a mixture of base, shoulder, and peaking units, the difference being in production costs, start-up costs, and minimum shut-down and start-up times. Peaking units would typically have the highest generation costs, medium start-up costs, and the shortest minimum start-up and shut-down times. Thus, it was expected that the algorithm would turn peaking units on only during daytime load peaks.

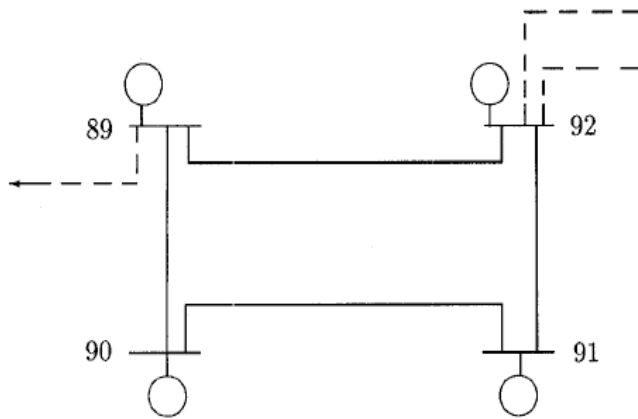

FIGURE 12

The network used was the IEEE 118-bus test system that is characterized by a high generator-to-bus ratio with 54 generators and 118 buses. The system is very flexible in terms of the ability of the system operator to dispatch reactive power when most generators are online. This, however, was not the case for the commitment schedules chosen by the algorithm for nighttime when the load is low; many generators were shut down and the system had much less flexibility for reactive dispatch. In particular, some of the optimum solutions found by the unit-commitment algorithm had peaking units committed at night. These units were dispatched against their lower operating limit since their real power is expensive, but their reactive capability was used without restraint.

In Figure 12, the units at buses 90 and 91 are peaking units and the unit at bus 89 is a big base-load unit that is always dispatched at its maximum operating limit. The unit at bus 92 is usually dispatched starting with the shoulder-load level but is offline at night. Furthermore, the path 89-90-91-92 has considerably more losses than the more direct parallel path 89-92. At nighttime, the optimum unit commitment dispatches the peaking units at buses 90 and 91 to better manage losses along the 89-90-91-92 path and help channel more of the real power being injected at bus 89 to the 89-92 line and then to the rest of the network. This pattern of optimal dispatch is unexpected and challenges traditional beliefs about standard unit-commitment procedures. If this network were to be used in a deregulated market setting, the two peaking units would have exactly the same type of market power discussed in the first example, which would inevitably lead to speculative behavior by controllers of these units.

3. Cascading Market Power

In a competitive market using the last (most expensive) accepted offer (LAO) to set the clearing price, the price-setter can raise the clearing price only as high as the price of the first rejected offer (FRO), and it is the competition between the first rejected and the last accepted offers that promotes honest marginal-cost offers. However, when there is congestion and there are only a few generators inside a load pocket, those generators have market power and can raise the clearing price by tacit collusion on the portion of the load inside the pocket that cannot be served by sources outside the pocket. Under certain topological configurations, it is possible that the ability to set higher prices in the load pocket “cascades” upstream along the paths of the congested transmission lines serving the load pocket and it may be possible for other generators to unilaterally raise their prices and profits thanks to this cascading effect.

Consider the modified version of the IEEE 30-bus system shown in Figure 13. In this case, area 1 is isolated by congestion. When the generators submit competitive (marginal-cost) offers, the resulting nodal prices, quantities dispatched, and earnings are shown in the boxes next to each generator in the figure. Since there is congestion, however, generators 1 and 2 only compete with one another in a duopoly for a portion of their local load and they may be able to obtain higher prices in area 1 through tacit collusion. For example, doubling the offer prices of generators 1 and 2 increases their earnings substantially, as can be seen in Figure 14. The local market power of these units in area 1 cascades to generator 4 on one of the major transmission lines supplying area 1 even though generator 4 is outside of the load pocket. Generator 4 can unilaterally increase revenue by raising its offer price, as shown in Figure 15. In addition, since generator 4 can set a high price for its own output, the topology of the network has reduced the effective number of competitors outside the load pocket from four to three.

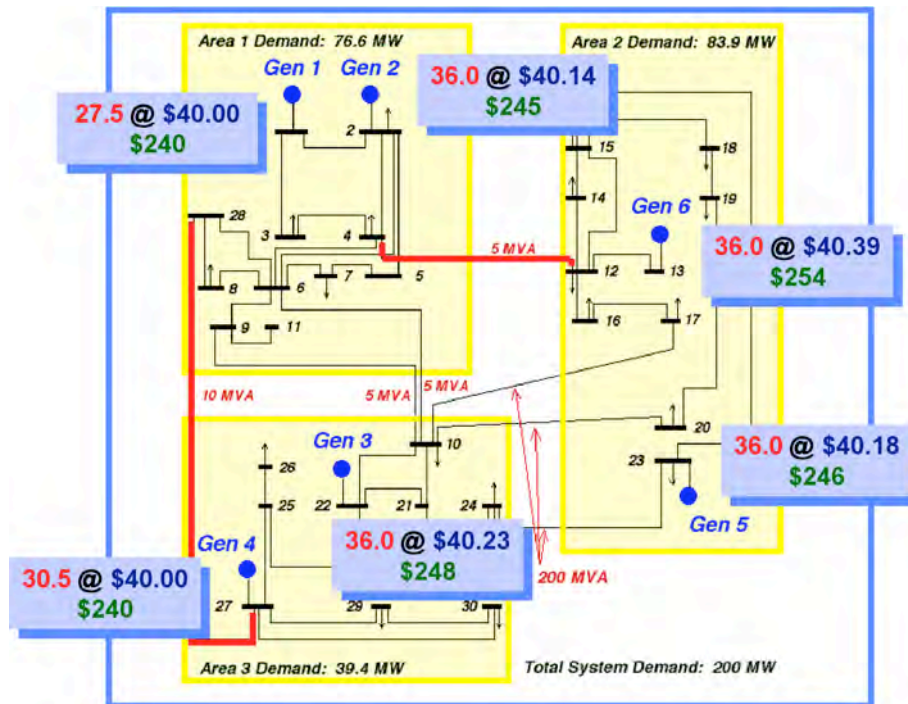

Figure 13. Cascading Market Power: Marginal Cost Offers

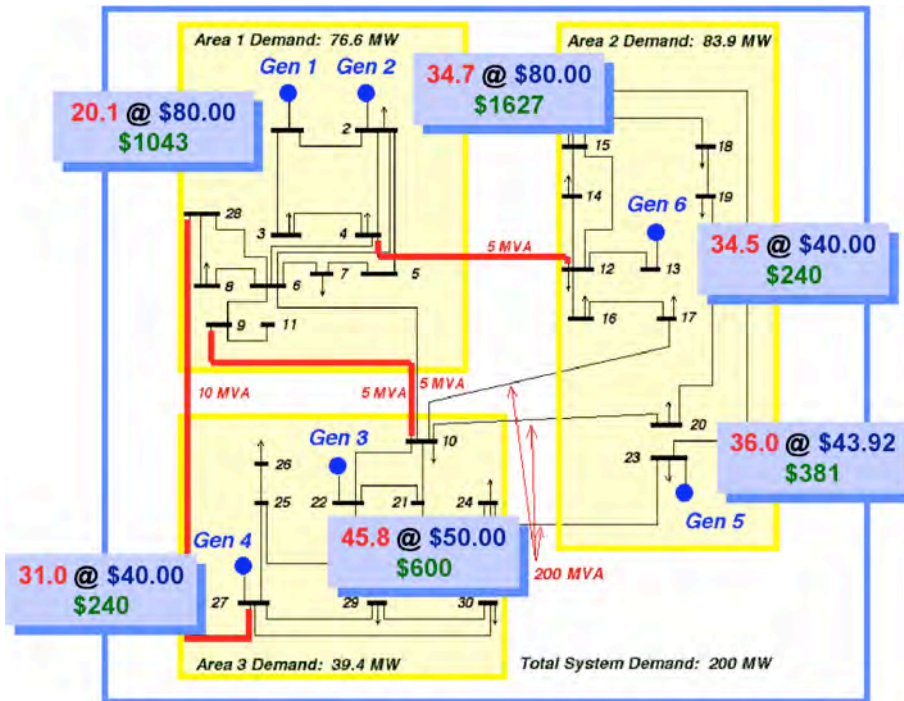

Figure 14. Cascading Market Power: Duopoly in Area 1

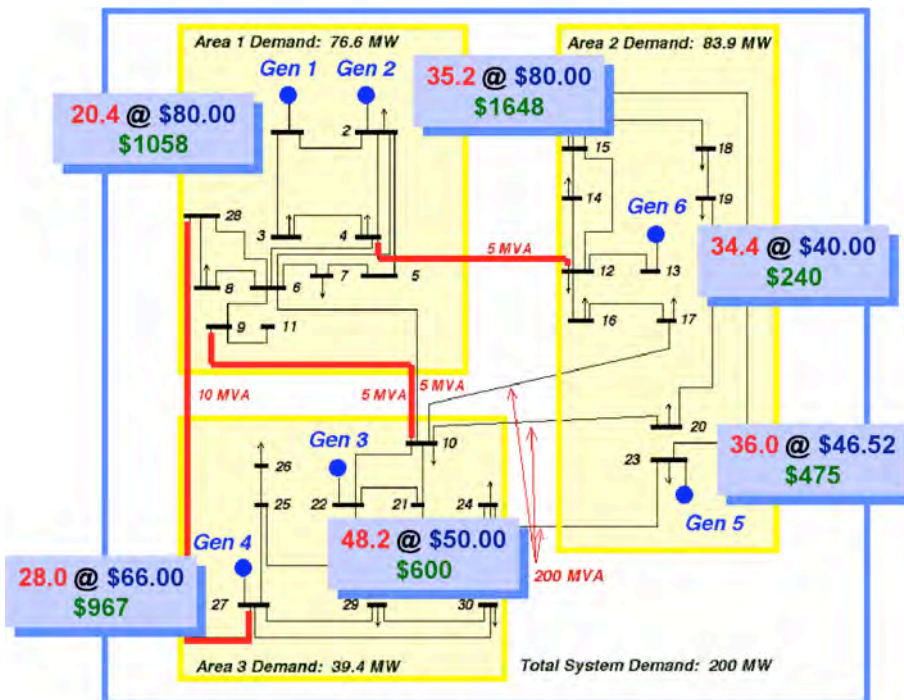

Figure 15. Cascading Market Power: Generator 4 Exerts Its Market Power

4. Complex Interactions among Constraints

In the previous example, the topology of the network was responsible for creating the noncompetitive situation outside the load pocket. The case we review now illustrates an even

more complex situation in which the interplay between congestion, reactive dispatch, and voltage limits conjugation and creates a rather anomalous situation. The system used is another modification of the IEEE 30-bus network and is shown in Figure 16. This time, it is area 2 that is isolated by congestion. Generator 6 has decided to withdraw all but the first block of power from the market. The transmission line joining buses 4 and 12 is maximally loaded, and because it is instrumental in the transfer of power from area 1 to area 2, most of its reactive-power capacity is needed to transfer real power. In other words, this line needs to be VAR-compensated to a unity power factor on both ends and this imposes important constraints on how much reactive power should be produced by generators 2 and 6 and, to a lesser extent, by generator 1. The high loads on buses 16 and 17 put a strain on the voltage profile at bus 17 and soon the reactive dispatch of generator 6 must respond to two conflicting requirements: increase production of reactive power to alleviate voltage problems at bus 17 or decrease it to compensate the near end of line 4-12 so that more of its transmission capability can be used. It is not possible to satisfy both objectives simultaneously because the line connecting bus 17 to bus 13 goes through bus 12, and the voltage of bus 12 is tied directly to how well line 4-12 is compensated.

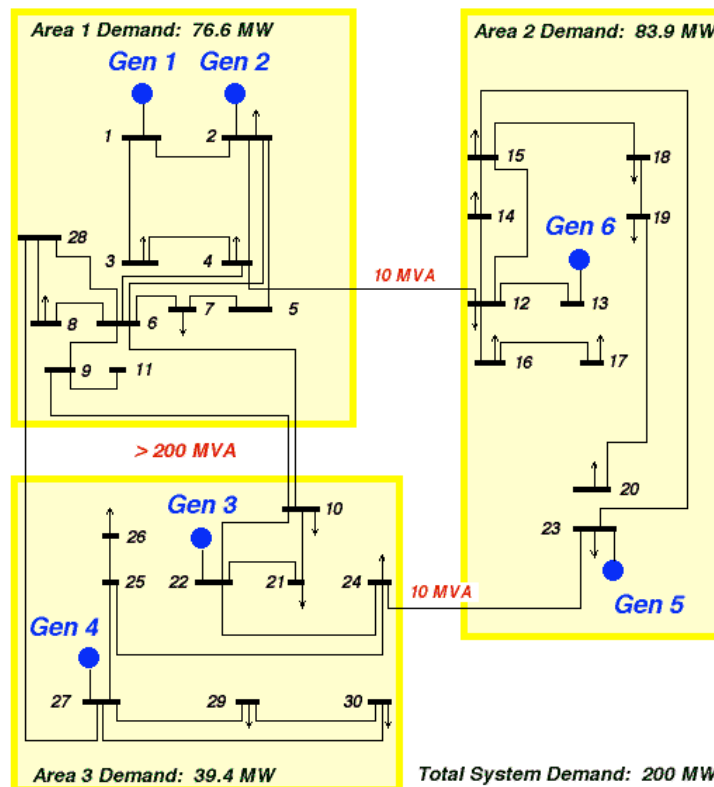

Figure 16. Constraint Interaction Example

The implications for nodal pricing are huge. The shadow prices on the thermal MVA limit for lines 4-12 are \$25.78 per MVA hour (MVAh) at the left end and \$75.32 per MVAh at the right end. The nodal prices for real power exceed \$110 per MWh at buses 12 through 20 as shown in Table 4 even though the highest-priced offer is only \$50 per MWh. Furthermore, the optimum dispatch of real power is highly sensitive to changes in load in area 2 because increasing the load by only one MW at bus 17 requires shifting several MWs from generator 2, which has low

production costs, to generator 4, which has high production costs. This shift of dispatch explains why the nodal prices of real power are so much higher than the offer prices.

Nodal prices for both real and reactive power are presented in Table 4 for all of the busses. Even though the prices of reactive power are relatively high at busses 15 through 20, the prices corresponding to the busses for nearby generators (13 and 23) remain zero. This illustrates two fundamental characteristics of the production of reactive power by generators. First, unlike the marginal cost of increasing production of real power, the cost of producing more reactive power is zero until output reaches the limits of the capability curve. When this constraint is reached, it is necessary to cut back on production of real power to produce more reactive power. The cost of producing this additional reactive power is the opportunity cost (lost profit) of selling less real power. The second characteristic is that the need for reactive power is highly localized. The marginal cost of supplying reactive power to the load at bus 17 is still high (\$15 per MVAh) even though the marginal cost of producing more reactive power from the nearest generator at bus 13 is zero.

TABLE 4

bus	$\lambda_P, \$/MWh$	$\lambda_Q, \$/MVAh$
1	39.7478	0.0000
2	40.0000	0.0000
3	39.4422	0.3510
4	39.1933	0.3390
5	40.8882	-0.0100
6	41.2846	-0.2614
7	41.5289	0.0161
8	41.5118	-0.2398
9	47.3331	0.2639
10	50.3960	0.7551
11	47.3331	0.2639
12	123.2880	0.0000
13	123.2880	0.0000
14	120.0322	0.4297
15	113.3498	2.0013
16	129.4817	7.9266
17	134.5626	15.0001
18	118.2896	3.9804
19	120.5773	4.8238
20	120.7994	4.8945
21	51.5922	-0.1201
22	52.0829	0.0000
23	88.9719	0.0000
24	64.8839	0.1527
25	55.0153	-1.2057
26	56.0494	-0.5153
27	50.0000	0.0000
28	42.0391	-0.7178
29	51.4759	0.4197
30	52.5006	0.5910

3.2 Potential Problems for Implementing a Market for Reactive Power

The four examples of network conditions presented in the previous section describe the complex characteristics associated with providing reactive power on a network and the surprising effects those characteristics can have on nodal prices for real power and the optimum commitment of units to meet load. The highly localized nature of the demand for reactive power, illustrated in Table 4 by the substantial differences in nodal VAR prices at busses that are relatively close together, suggests that suppliers of reactive power are likely to have market power in the type of auction typically used for real power. Hence, there are two problems related to market power that should be investigated before trying to implement the type of real-time market proposed by FERC First is the potential effects of speculative behavior in a VAR market on nodal VAR prices. Second is the indirect effects of speculative behavior in a VAR market on the suppliers' level of market power in the market for real power.

The optimum design of a network derived in Section 2 provides additional insight into the likely characteristics of a market for reactive power. Efficient nodal prices for reactive power are zero most of the time (see Figure 10). Nodal prices are not zero only when contingencies occur due to the failure of transmission lines. When the system is intact, the "static" reactive power needed for transmission is supplied mainly by capacitors/inductors because this type of equipment is relatively inexpensive to install. It is only when a contingency occurs and the system is stressed that there is a demand for "dynamic" reactive power, which is typically provided by generators. The overall implication is that paying the efficient nodal prices for reactive power would provide a highly volatile source of revenue for firms supplying dynamic reactive power. They would get paid only in emergencies.

Unlike production costs for real power, production costs for reactive power are zero as long as the dispatch is within the limits set by the capability curve (see Figure 4). This is why the nodal VAR prices shown in Table 4 are zero for all six generators. The nodal VAR price for a generator, on the other hand, can be extremely high once the VAR limit on the capability curve is reached. Whenever this occurs, there is sufficient demand for reactive power at that location to make it efficient to reduce the output of real power from the generator. The nodal VAR price for the generator is determined by the opportunity cost of re-dispatching other units on the network to replace the reduction in real power from the generator. As the fourth example in the previous section illustrates, this opportunity cost can be very high and also can result in substantially higher nodal prices for real power.

We conducted a series of experiments as a pilot test of the performance of a market for real and reactive power using a version of the IEEE 30-bus network shown in Figure 16. Market participants for these experiments (tests 1, 2, and 3) were students enrolled for fall 2005 in AEM 655/ECE551: Power Systems Engineering and Economics and were masters and doctoral students from the Department of Applied Economics and Management and the School of Electrical and Computer Engineering at Cornell University. Tests 1 and 3 were conducted with two separate groups of six students each who represented the six generators on the network. Test 2 was conducted with one group of six students. All three tests were conducted in Cornell's Laboratory for Experimental Economics and Decision Research. To provide realistic financial incentives, all participants were compensated with salient monetary rewards corresponding to a percentage of the profit they earned in each test (Siegel and Goldstein, 1959). The shared characteristics of the three tests can be summarized as follows.

- In all tests an AC OPF determined nodal prices and dispatch to minimize the cost of meeting load in a uniform-price auction (last accepted offer) using the POWERWEB software platform (see Zimmerman et al., 1999).
- In all tests each generator controlled three generating units (low-, medium-, and high-cost).
- In all tests the independent system operator (ISO) was the sole buyer of electricity and the pattern of load was exogenous and varied from one trading period to the next.
- Nodal prices had to be at least as high as corresponding offer prices, but offer prices and the prices paid were restricted to levels below the specified price caps.
- Each test was conducted for a total of 60 trading periods—30 periods for Treatment A and 30 periods for Treatment B.

In the following description of the three tests, the terms “energy” and “VArS” are used throughout to represent real and reactive power, respectively.

Test 1: Pay real time nodal prices for energy and a contract price of \$5 per MVar for VArS

This test corresponds to typical arrangements that are currently used to procure VArS in the transition from a regulated to a deregulated market.² It is consistent with FERC’s preliminary recommendation that “for the present, while spot price auction markets are being further studied, we recommend paying real time prices for actual reactive power production based on the provider’s own opportunity cost or based on administratively determined prices announced in advance, in order to encourage suppliers to produce reactive power where it is needed.”³

In this test, the ISO executes contracts with suppliers to provide VArS at a predetermined price whenever needed. The maximum amounts of VArS (positive and negative) that can be provided by each generating unit are known by the ISO (i.e., the ISO and the supplier agree on a specific capability curve for each unit and that curve limits production of VArS from a unit even if some of the capacity for energy is withheld from the auction). Since the price and maximum quantities of VArS for each unit are determined in a contract, the supplier’s decisions are limited to specifying the price and quantity offers for energy only. The maximum allowed price offer (and the price paid) is \$100 per MWh for energy.⁴ Note that this experiment also approximates the outcome of a contingent claim market for reactive power.

Test 2: Pay real time nodal prices for energy and nodal prices for VArS

This test corresponds to FERC’s current proposal to introduce a new market for selling VArS in the transition to deregulation. In this market, the ISO determines optimal patterns of dispatch for energy and VArS by minimizing the cost of meeting load using the price/quantity offers for energy and price offers for VArS as the costs. The maximum VAr capabilities (positive and negative) that can be produced by each generating unit are known by the ISO (i.e., suppliers cannot withhold VAr capacity and the ISO and the supplier agree on a specific capability curve

² This is also the approach used to procure reactive power in the United Kingdom and in India.

³ *ibid.* p. 15[[no reference prior for the *ibid*; not sure what this refers to]]

⁴ This is consistent with FERC’s suggestion to “cap the suppliers’ bids [sic] while allowing all accepted suppliers to receive a market-clearing price in the spot market that reflects the highest accepted bid.” (p.15)[[what work does this refer to?]]

for each unit, which limits production of VARs from a unit even if some of the capacity for energy is withheld from the auction). In this market, participants are paid nodal prices for energy and for VARs for the dispatched quantities. The maximum allowed price offers (and the prices paid) are \$100 per MWh for energy and \$50 per MVAR for VARs.

Test 3: Pay real time nodal prices for energy and nodal prices for VARs in a market with:

- 1) interruptible load, and*
- 2) dispatchable sources of VARs.*

The auction for energy and VARs is the same here as it is for test 2. The basic rationale for this test is that regulators were concerned about the ability of firms to exploit a market for VARs in test 2. As a result, they have decided to make the market more responsive to high offer prices by (1) having 30 MW of interruptible load distributed around the network (used if the price of energy reaches \$75 per MWh) and, as an alternative, (2) having 30 MVARs of dispatchable sources of VARs distributed around the network (and paid \$25 per MVAR if dispatched). This test is conducted to see which approach is the most effective way to mitigate market power in the VAR market. Note that periods 1 through 30 test interruptible load and periods 31 through 60 test dispatchable sources of VARs.

Within-Test Treatments

Tests 1 and 2 contain two treatments, each lasting for 30 trading periods. The first treatment uses normal capability curves, which represent operating conditions in which there is ample capability to supply VARs. In the second treatment, the total VAR capability of the generating units is reduced to two-thirds of the amount available in the first treatment. This has the effect of shifting the capability curve inward and creating a potential shortage of VAR production. These restricted capabilities represent operating conditions when the system is stressed due to contingencies and there is a need for “dynamic” VARs. In test 3, the restricted capability curves are used for all trading periods and the first treatment corresponds to interruptible load and the second to dispatchable sources of VARs.

3.3 Results from the Pilot Tests of a Market for Energy and VARs

Test 1 can be thought of as the base case because the nodal VAR prices reflect the true opportunity costs of procuring reactive power.⁵ Figure 17 demonstrates that the nodal VAR prices for the six generators are close to zero most of the time (reflecting the true marginal cost of production when a generator is not on the capability curve) and are occasionally very high (reflecting the opportunity cost of being on the capability curve).⁶ Not surprisingly, the second treatment, in which there is less VAR capability available in the system, produces higher VAR prices when load is high and the network is more congested.

⁵ Generators submit price/quantity offers for energy and are required to supply VARs when needed. They are paid the nodal price for energy and a fixed price for VARs through a contract with the ISO. Note that, while reactive power is being bought at a fixed contract price of \$5 per MVAR, the nodal prices reported here are the true opportunity cost of supplying VARs.

⁶ Competitive VAR prices based on true marginal costs are only greater than zero on the capability curve.

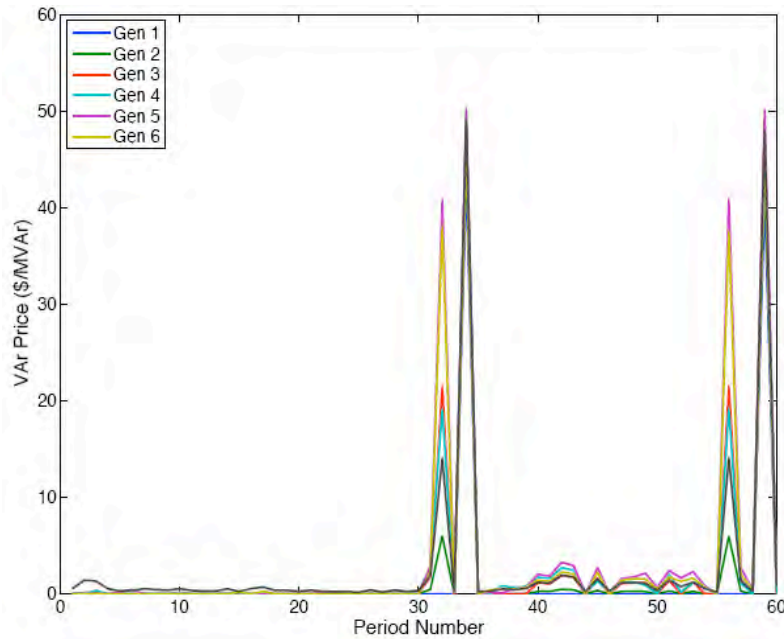

Periods 1–30: Normal Capability Curves
 Periods 31–60: Restricted Capability Curves

Figure 17. Nodal VAR Prices for Six Generators in Test 1

In test 2, the suppliers were allowed to submit separate offer prices for VARs and for energy. The maximum offer allowed was set at \$50 per MVAR, and suppliers were not allowed to submit VAR quantity offers. From Figure 18, we see that nodal prices paid to generators were substantially higher than they were in test 1. The fact that the nodal VAR prices were greater than zero most of the time, and therefore did not reflect the true cost of producing VARs, shows that suppliers were able to exercise market power effectively. Furthermore, the differences in VAR prices paid to individual generators also increased substantially.⁷ These results highlight the concerns raised earlier that a market for VARs would be susceptible to the exercise of locational market power by generators due to the fact that VARs do not travel long distances economically.⁸

⁷ In test 2, generator 6 made large profits by offering VARs to the market at prices that were around \$15 to \$25 in all trading periods. Using this strategy, generator 6 was still dispatched for VARs most of the time and received a high market price. In contrast, generator 3 offered VARs for all three generating units at very low prices (almost all were below \$3, with some as low as \$0.2). This strategy was not successful because the resulting VAR prices paid to this generator were also low.

⁸ Allowing generators to submit price and quantity offers for VARs could potentially lower available VAR capability and create even greater opportunities for exploiting market power.

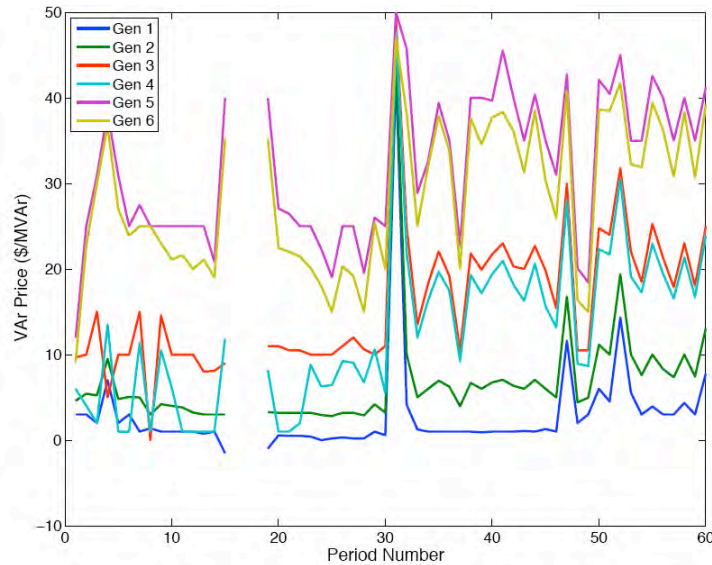

Periods 1–30: Normal Capability Curves

Periods 31–60: Restricted Capability Curves

(Gaps in the sequence correspond to trading periods in which the software did not find a solution.)

Figure 18. Nodal VAR Prices for Six Generators in Test 2

With concerns about the exercise of location-based market power by generators realized in test 2, the justification for evaluating ways to mitigate market power in test 3 is obvious. In test 3, two approaches were used to make the market more responsive to high offer prices for VARs: (1) having 30 MW of interruptible load distributed around the network and (2) having an additional 30 MVAR of dispatchable VAR capability. The first approach has the potential to mitigate market power in the markets for both energy and VARs because loads are specified with constant power factors (i.e., purchases of energy and VARs by loads are strictly proportional). With the second approach, giving the ISO more flexibility for meeting VAR needs makes it less likely that expensive sources of VARs will be dispatched.

From Figures 19 and 20, we see that interruptible load (periods 1–30) led to a general downward trend in nodal VAR prices for all six generators. Using dispatchable sources of VARs (periods 31–60), nodal VAR prices remained low for group 1, but for group 2 there were a number of high-price spikes due to importation of expensive VARs from other regions (this feature was added to PowerWeb to try to ensure that feasible solutions could be found when suppliers withheld a large amount of capacity from the market). Although nodal VAR prices were still greater than zero most of the time for all generators and there still was no incentive to submit “honest” offers for VARs, both approaches to mitigation in test 3 did reduce the ability of generators to exploit market power. Average nodal VAR prices were lower than they were in test 2, and they exhibited smaller location-based differences and also were less erratic, particularly for group 1. These results suggest that incorporating either interruptible load or dispatchable sources of VARs may be an effective way to limit market power in a VAR market.

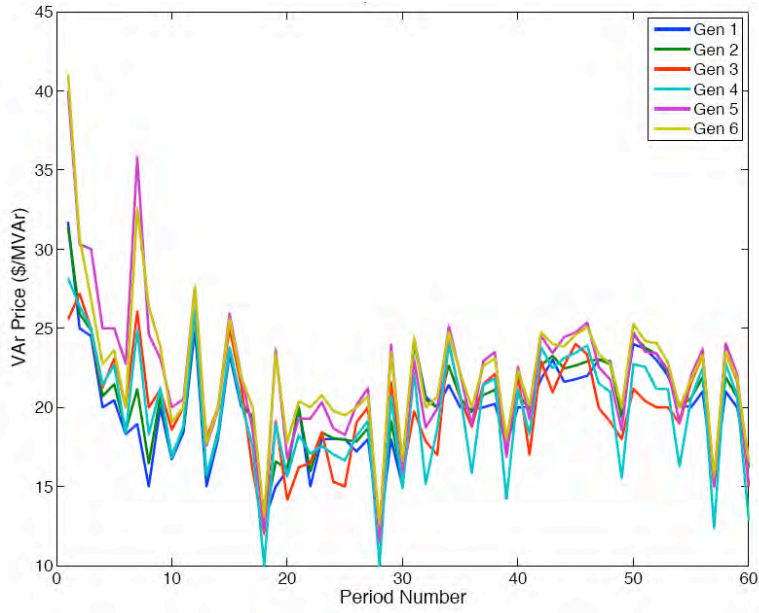

Periods 1–30: Interruptible Load
 Periods 31–60: Distributed Sources of VARs

Figure 19. Nodal VAR Prices for Six Generators in Test 3, Group 1

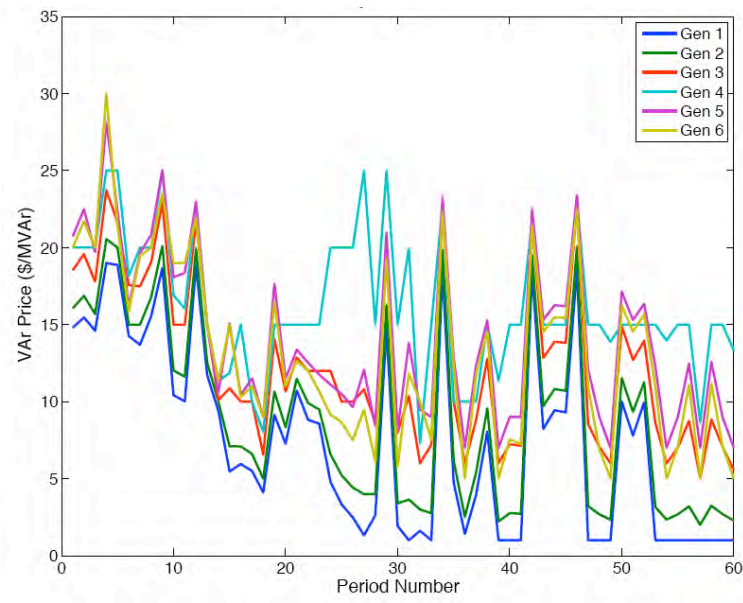

Periods 1–30: Interruptible Load
 Periods 31–60: Distributed Sources of VARs

Figure 20: Nodal VAR Prices for Six Generators in Test 3, Group 2

Average VAR prices paid to generators in the three tests are summarized in Table 5. In addition, average competitive prices are presented that are based on submitting the marginal-cost offers for both energy and VARs. It is important to note that, while the contract price for VARs in test 1 has the lowest average cost for the ISO compared to the other two tests, true nodal VAR prices

are very erratic and not a very attractive source of revenue. Also, the contract price of \$5 per MVAR was chosen arbitrarily and there is no guarantee that it is high enough to provide the investment incentives necessary to increase VAR capabilities when they are needed.

Table 5: Average Reactive-Power Prices

	Test 1				Test 2		Test 3			
	Group 1		Group 2		Group 1		Group 1		Group 2	
Reactive Power	Period A	Period B	Period A	Period B	Period A	Period B	Period A	Period B	Period A	Period B
Average Price \$ per MVAR	5.00	5.00	5.00	5.00	11.06	22.63	13.59	9.97	20.02	21.40
Average Comp. Price \$ per MVAR	5.00	5.00	5.00	5.00	0.003	5.12	4.64	3.31	4.64	3.31

Period A: Trading periods 1–30. Period B: Trading periods 31–60.

Comparing average VAR prices in Table 2 raises the question of whether the greater investment incentives provided by higher but still erratic VAR prices in tests 2 and 3 would provide justification for introducing a market for VARs. Since the generators will almost certainly possess market power in a VAR market and have no incentive to submit “honest” offers, nodal VAR prices in tests 2 and 3 will be substantially above competitive levels (since competitive prices for VARs are generally zero, suppliers face much less of a penalty for submitting high offer prices for VARs than they do for energy). When it is necessary to allow suppliers to exercise market power to get adequate investment incentives in a market, the question for regulators is how much market power should be permitted.⁹

3.4 Summary Comments

The simple yet principles-based examples and tests previously described illustrate some of the problems with physical operation of a network that can undermine the conditions needed to support a competitive market. These problems have direct consequences for the existence of market power and reactive power plays an important role in most of them. Also, the specific topology of a network can cause more problems than expected, as illustrated by the example of cascading market power. The main conclusion is that all network complexities, including the topology and reactive dispatch, should be integral parts of the design of a robust market for real power and ancillary services if such a market is to produce just and reasonable prices for customers. These complexities should not be treated as an afterthought.

Simple tests of markets for reactive (and real) power show that suppliers can identify and exploit situations when they possess market power. Suppliers have incentives to under invest in reactive-power capacity since this will keep prices high. An underlying issue for designing a market is that, under competitive conditions, the highest payments for supplying reactive power occur rarely—when the network is operating under stress and/or when contingencies occur. Sources of dynamic reactive power are essential to maintain operating reliability and avoid expensive

⁹ These high prices could be justified using long-run efficiency as the regulatory objective.

outages. However, our preliminary results suggest that it is unlikely that a market for reactive power will give the right price signals to maintain reliability. Clearly, it is premature to consider implementing a new market for reactive power at this time without first completing an extensive set of additional experimental tests and evaluations of alternative market designs.

4. Conclusions and Recommendations

The theoretical structure, simulations, and experiments presented in this paper provide the following conclusions.

- 1) Although network reliability has long been identified as a public good, voltage and frequency have not because of, among other reasons, the incomplete nature of existing DC models. The modeling and simulations presented here demonstrate the public-good nature of voltage and reliability of lines. Note that, except under special circumstances, private incentives for provision of public goods are insufficient and efficient provision requires some central authority.
- 2) Both real power and reactive power are technically private goods since they are excludable and rival. Thus, unlike voltage and reliability, well-designed private markets are theoretically efficient if the public goods needed to support the system are optimally provided.
- 3) Simulation of optimal operation under different contingencies demonstrates that nodal reactive-power prices are almost always equal to zero if optimal investment in reactive-power sources (e.g., generators and reactive-power compensators) occurs throughout the system. Nonzero reactive-power prices, which optimally are found only during contingencies, such as when failures occur, remain relatively low because of the low cost of investment in a reactive-power supply.
- 4) The average or expected revenue derived from sales of reactive power at optimal real-time prices during rare contingencies is sufficient to provide incentives for optimal private investment in reactive-power capacity. However, this is a highly volatile and unpredictable source of revenue that depends on such rare contingencies actually occurring. Thus, private investments in reactive capacity are inherently risky investments. When reactive capacity is in short supply, the willingness-to-pay, or social value, for reactive power is many orders of magnitude greater than the investment based on the cost per unit during contingencies, so it is optimal to make large investments in reactive-power capacity to prevent shortages even during rare contingencies.
- 5) However, both simulations and economics experiments show that opportunities for the exercise of market power by private suppliers of reactive power in real-time markets are plentiful in a network environment in which transmission of reactive power is limited to short distances, as established by Kirchoff's laws. Thus, even with sufficient reactive-power capacity, suppliers are likely to submit offers that produce positive real-time reactive-power prices in noncontingency states for which the optimal price is zero.
- 6) Whereas virtually all demand for real power comes from private buyers, demand for reactive power comes from two sources: demand from private buyers to meet the needs of motors, arc welders, and other equipment and the often greater demand from the central authority acting in the public interest as an input to the provision of a public good—voltage. Thus,

since voltage is essential for reliability, reactive power plays a special role in the security of the power system.

- 7) Optimal real-power prices show greater upside volatility than optimal reactive-power prices, principally because investment in generation is so expensive that it cannot optimally cover all contingencies. Optimal investment in generation does conform to the conventional wisdom of covering the worst single contingency by meeting load with the loss of the “largest” generator in the simulation. However, peak prices during some contingencies are much higher for real power because optimal investment in capacity cannot efficiently cover load with the loss of multiple generators. Note that optimal investment will occur in a free market only when prices are not capped since the next-to-worst-case scenario for generator failure provides the incentive for investment in the surviving generator to provide optimal reliability through prices on the order of \$10,000 per megawatt hour.
- 8) In the simulation, optimal investment in lines is sufficient to prevent thermal line constraints from binding, even during contingencies. Thus, if a DC optimal power flow were to be used, there would be no transmission fees since nodal prices would all be the same. However, a full AC power flow does show substantially different nodal prices for real and reactive power but only during contingencies. Transmission fees must equal nodal price differences for real and reactive power from a full AC power flow if they are to provide both revenue and charges for reactive power consumed by lines (to maintain voltage) that will generate optimal incentives for investments in lines.

Before making recommendations based on the preceding conclusions, we note that there is more than one deregulated market design that can be used to try to maximize economic efficiency. Table 6 shows three such designs. Design A is a day-ahead/real-time market for both real and reactive power with real-time auctions for both forms of power. It also can contain advance auctions (e.g., hour-ahead, day-ahead). It uses the real-power system lambdas as prices for real power and the reactive-power system lambdas as prices for reactive power. These prices guide the production, consumption, and investment decisions of market participants. Retailers have an incentive to try to pass price signals on to their customers via retail real-time metering, optional automatic interruptible service on appliances such as air conditioners, and reliability-differentiated service, which were described earlier in this paper. Retailers may charge location-based prices. They also may practice “price discrimination,” which involves either allowing customers to choose from more than one rate structure or offering different rates to different entities based on one or more characteristics such as monthly electricity consumption. Offers in the reactive-power market may be either chosen by the owners of the reactive-power-producing equipment or set equal to the marginal cost of reactive power from the equipment, including the lost opportunity cost.

Design B is a contingent-claim market for both real and reactive power. In it, the supply owners offer control of their units to the system operator for a fixed number of months or years in a periodic auction. The system operator chooses the optimal combination of units. An option is to hold the auction enough years in advance to allow participation of units that would be built only if the supplier won the auction. This would reduce market power and encourage adequate supply investment (Adilov, 2006). For both real and reactive power, the system operator gives the owner of each winning unit a location-based, market-clearing capacity payment determined by the offers in the auction and the characteristics of the system. This location-based payment is

greatest where capacity is most needed, providing an incentive for capacity installation there. During operation, the system operator reimburses unit owners for the variable costs of producing the real and reactive power they provide. To encourage generator owners to maintain and operate their units well, the system operator can require that offers specify the heat-rate function of the unit and that the owner must pay the cost of any excess fuel needed if the unit exceeds the heat rate specified by that function.

Design C is a hybrid of designs A and B. It uses day-ahead/real-time auctions for real power and a contingent-claim market for reactive power. Reactive-power production can involve variable costs, including lost opportunity costs, so the system operator reimburses reactive-power providers for these variable costs.

Design D is traditional cost-based regulation with an option for features such as performance-based rate-making and competitive procurement. It is not included in Table 6. Market power may be less of a problem under this design, and profit motives are not at odds with reliability. However, the incentives for efficient investment and operation must be created by regulators.

Table 7 summarizes the status quo in restructured U.S. ISO/RTO systems. It is a version of design C. However, in the status quo, the compensation that suppliers receive for their reactive capacity is either an estimate of its annualized fixed cost or zero. This is different from the location-based market-clearing prices for reactive capacity used in designs B and C. As a result, the status quo misses an opportunity to provide an incentive for reactive capacity installation where it is most needed. The status quo deregulated market design in the U.S. includes a cap on wholesale electricity prices. A cap can reduce the amount of peaking generation by making it unprofitable. This reduces system reliability and may increase average prices. If high electricity price spikes are politically unpalatable, an alternative means of suppressing them is an auction for curtailment and/or system-operator-controlled generation. The system operator can run this auction and can fund it with a surcharge on all customers. In the market, customers who are willing to have interruptible service can submit offers indicating the minimum they would have to be paid to accept automatic curtailment. Those whose offers are accepted would be cut off by the system operator when necessary to suppress prices and would be compensated for it at the price determined in advance by the auction. In addition, or instead, the system operator can procure some peak generation and offer it into the power auctions at margin. Correct reactive-power flows are essential for preventing blackouts and equipment damage from abnormal voltage. Therefore, adequate supply and control of reactive power are crucial.

Table 6. Proposed Designs for Restructured Electricity Markets

A. Day-ahead/real-time market for real and reactive

	<u>Wholesale sellers</u>	<u>System operator</u>	<u>Wholesale buyers</u>	<u>Retail buyers</u>
Real power	Submit offers into auctions. Receive market-clearing location-based prices. Private entities install units based on expected future prices.	Runs uniform-price auctions: day-ahead and real-time.	Choose how much to consume at real-time, market-clearing, location-based prices.	Retail prices are set by marketers. There are opportunities for location-based pricing, discriminatory pricing, and reliability-differentiated service.
Reactive power	Two options: units submit reactive-power offers or offers are calculated implicitly from the lost opportunity cost. Units receive market-clearing location-based prices. Private entities install units based on expected future prices.	Runs auction. Calculates optimal real- and reactive-power injections using AC OPF that includes voltage and reactive power.	Each customer pays real-time, market-clearing, location-based prices for reactive power the customer consumes.	

B. Contingent-claim market for real and reactive

	<u>Wholesale sellers</u>	<u>System operator</u>	<u>Wholesale buyers</u>	<u>Retail buyers</u>
Real and reactive power	Offer control of units (generators, reactive compensation equipment, etc.) to the system operator in periodic auctions. Maintain and operate units. Optionally, auction can be years in advance to allow for the participation of units that will be built only if they are chosen in the auction.	In periodic contingent-claim auctions, chooses optimal combination of offers. In real time, operates a uniform-price auction. Offers all units' output into the auction at marginal cost. Calculates and dispatches optimal real- and reactive-power injections using AC OPF that includes voltage and reactive power.	Buy from system operator at market-clearing location-based prices.	Retail prices are set by marketers. There are opportunities for location-based pricing, discriminatory pricing, and reliability-differentiated service.

C. Day-ahead/real-time for real and contingent-claim for reactive

	<u>Wholesale sellers</u>	<u>System operator</u>	<u>Wholesale buyers</u>	<u>Retail buyers</u>
Real power	Submit offers into auctions. Receive market-clearing location-based prices. Private entities install units based on expected future prices.	Continually operates uniform-price auction for real and reactive power. Calculates and dispatches optimal real- and reactive-power injections using AC OPF that includes voltage and reactive power.	Choose how much to consume at real-time, market-clearing prices.	Retail prices are set by marketers. There are opportunities for location-based pricing, discriminatory pricing, and reliability-differentiated service.
Reactive power	Offer control of reactive-power output to system operator in periodic auctions.	In periodic (e.g., annual) contingent-claim auctions for reactive power, chooses optimal combination of offers. Offers all units' reactive output into real-time auction at marginal cost.	Buy from system operator at market-clearing prices.	

Table 7. Status Quo Market Design in Restructured U.S. ISOs/RTOs

	Wholesale sellers	System operator	Wholesale buyers	Retail buyers
Real power	Hour-ahead and real-time uniform-price auctions with price cap. Also, bilateral contracts. Receive installed capacity payments to attract and retain sufficient generation capacity.	Runs auction; sets price cap.	Hour-ahead and real-time uniform-price auctions with price cap. Also, bilateral contracts.	Most pay fixed prices that vary only as summer and nonsummer.
Reactive power	Generators required to provide VARs within a range. In some systems, they receive administratively determined capacity payment. In some systems, they receive lost opportunity costs if asked to operate outside required range.	Determines reactive-power injections and sets the compensation paid to wholesale sellers and the charges paid by wholesale buyers.	Charged for reactive power in proportion to individual average or peak purchase of real energy. In some ISOs/RTOs, the charge is real-time and/or location-based.	Charged for reactive power in proportion to individual average or peak consumption of real energy.

To secure adequate supply and control, the system operator must master the difficult task of providing appropriate incentives. Furthermore, although the cost of producing reactive power may be small compared to the total cost of electricity service, it is still substantial and the design of reactive-power markets is critical because the benefits of provision are many orders of magnitude greater than costs.

Given the market options previously described and our research conclusions, we recommend the following course of actions.

- 1) The first conclusion presented—that some central authority is needed to provide the public goods of reliability and voltage (as well as frequency)—implies that electric power does not lend itself to the degree of decentralized decision-making present in typical markets. Thus, there must be some institution that has government-like authority to design, plan, and manage the system. This entity is referred to as the central authority because independent system operators currently do not have authority for planning and design.
- 2) For the central authority to act in the public interest and be able to optimize the system, as well as provide necessary public goods, a robust AC OPF program that can handle both the real-power and the reactive-power problems properly is needed. It should cover both unit commitment and contingencies. A proper OPF is needed to give an accurate picture of the system for operations as well as accurate price information for real power, reactive power, and transmission. Accurate prices are necessary to allow for proper investment decisions regarding generation, reactive compensation, and transmission. A major research and development program should be undertaken to provide this capability.
- 3) The third conclusion states that reactive-power prices will mostly be zero. When a real-time market for a private commodity has financial transactions on rare occasions, since markets are expensive to operate, natural economic forces will restructure the market to avoid

transaction costs. The commodity used in these markets is called a contingent claim, which is a claim for services that can be made only if one or more specified events occur. Contingent-claim markets operate well in advance of the contingencies that justify claims; are the normal replacement for real-time markets, which rarely have transactions; and are the appropriate type of market for reactive power. In a contingent-claim market, the central authority essentially rents major reactive-power sources from the suppliers that submit the lowest-priced offers and instructs owners how to operate those sources in real time. For generators, the contingent-claim contract can provide fixed compensation for reductions in real-power output if reactive-power needs require such reductions.

- 4) Because the central authority responsible for reliability and operations needs reactive power on demand to deal with contingencies and provide reliability (conclusion 6) but substantial investment to meet that demand must be assured in advance (conclusion 4), the reactive-power market must be run well in advance of any contingency to assure needed supply. Contingent-claim markets are appropriate for reactive power because they close well in advance of any claims made and, if run sufficiently far in advance, can provide a sure source of revenue, which encourages investment. Rather than obtaining revenue through rare and unpredictable contingencies, sources that submit winning offers obtain steady revenue in the form of rent to compensate them for providing reactive power on demand. Since this market is run far in advance, the central authority must determine projected reactive-power needs both for private buyers and for maintaining voltage. Thus, based on a determination of reactive-power needs (projected nodal demand) by the central authority (of how much and where), this market must be run locally to acquire reactive-power sources.
- 5) Market power is a serious problem for reactive power (conclusion 5) in real-time markets, more serious than for real power. Overall demand for reactive power comes in great part from the central authority responsible for system operations and reliability. Competitive prices will be assured in contingent-claim auctions only if some offered units are potentially excluded. We recommend that contingent-claim auctions for reactive power be run sufficiently far in advance (three to five years) to allow construction to occur so that existing suppliers are placed in competition with potential investors and new sources of reactive power, encouraging competitive prices.
- 6) Although real-time markets for real power are potentially feasible and can provide stable revenue for investment in generation through forward markets, capped real-power prices paid to generators, as is common in U.S. power markets, do not provide sufficient incentives for investment in generation to assure optimal reliability. Thus, we support measures to supplement generation investment if prices to generators are capped. Although a number of approaches are being tried to encourage investment in generation, it is not yet clear if any are successful or cost effective.
- 7) The central authority responsible for reliability and operations must have legal authority to impose the stringent penalties necessary to enforce contracts purchased in contingent-claim markets.
- 8) To provide incentives for conservation of real- and reactive-power demand, large-scale customers and marketers should pay real-time nodal prices for real and reactive power as derived from the system AC OPF. Marketers will then have incentives to optimally install metering and then either pass on real-time prices or install automated controls on customer

equipment in exchange for a lower fixed rate. This will make distributed energy resources and load response much more economically viable.

- 9) Nodal prices from a DC power flow provide incorrect price signals for investment in lines. Proper incentives require fees for transmission of real and reactive power that are equal to the nodal price differences for real and reactive power derived from a full AC power flow. Transmission also must pay for reactive power consumed by lines. Note, however, that transmission fees are typically near zero with optimal line investment and are positive only during contingencies. As in the case of reactive-power markets, real-time markets may not be appropriate. To assure efficiency and reliability, the central authority must plan and manage transmission.

References

- [1] Adilov, N., "Forward Markets, Market Power, and Capacity Investment," working paper presented at the fourth annual International Industrial Organization Conference, Boston, MA, April 7–9, 2006[[[cited as 2005]]]. Available at http://gemini.econ.umd.edu/cgi-bin/conference/download.cgi?db_name=IIOC2006&paper_id=72.
- [2] Alsac, O., B. Stott, "Optimal Load Flow with Steady-State Security," *IEEE Transactions on Power Apparatus and Systems*, vol. PAS 93, no. 3, pp. 745–751, 1974.
- [3] Bernard, J., T. Mount, W. Schulze, "Alternative Auction Institutions for Electric Power Markets," *Agricultural and Resource Economics Review*, 27(1998):1–7.
- [4] Cardell, J., C. Hitt, W.W. Hogan, "Market Power and Strategic Interaction in Electricity Networks", *Resource and Energy Economics*, 19(1997):109–137.
- [5] Caves, D.W., J.A. Herriges, R.J. Windle, "Customer Demand for Service Reliability in the Electric Power Industry: A Synthesis of the Outage Cost Literature," *Bulletin of Economic Research* 42(1990):79–119.
- [6] Doane, M., R. Hartman, C. Woo, "Households' Perceived Value of Service Reliability: An Analysis of Contingent Valuation Data," *The Energy Journal* 9(1988a[[[1998?]]]):135–151.
- [7] Doane, M., R. Hartman, C. Woo, "Household Preference for Interruptible Rate Options and the Revealed Value of Service Reliability," *The Energy Journal* 9(1988b[[[1998?]]]):121–134.
- [8] Ethier, R., T. Mount, W. Schulze, R. Thomas, "A Uniform Price Auction with Locational Price Adjustments for Competitive Electricity Markets." *Inter-national Journal of Electrical Power and Energy Systems* 21(1999):103–110.
- [9] Goett, A.A., D.L. McFadden, C. Woo, "Estimating Household Value of Electrical Service Reliability with Market Research Data," *Energy Journal* 9(1988):105–120.
- [10] Hartman[[[listed as Hartmen in citation]]], R.S., M.J. Doane, C. Woo, "Consumer Rationality and the Status Quo," *Quarterly Journal of Economics* 106(1991):141–162.
- [11] Hogan, W., "Contract Networks for Electric Power Transmission," *Journal of Regulatory Economics* 4(1992a):211–242.
- [12] Hogan W., "Markets in Real Electric Networks Require Reactive Prices," *The Energy Journal* 14(1992b):211–242.
- [13] Hogan, W.W. "Transmission Market Design," KSG Faculty Research Working Papers Series RWP03-040, 2003.
- [14] Hogan, W.W. "Successful Market Design ("SMD") and Failure Diagnosis: Blackouts and Lampposts in Regulating Electricity Markets," Center for Business and Government, October, 2003.
- [15] Joskow, P., R. Schmalensee, *Markets for Power: An Analysis of Electric Utility Deregulation*, MIT Press, 1983.
- [16] Kleindorfer, P., C. Fernando, "Peakload Pricing and Reliability under Uncertainty," *Journal of Regulatory Economics* 5(1993):5–24.

- [17] Kleindorfer, P., D. Wu, C. Fernando, "Strategic Gaming in Electric Power Market," *Proceedings of the 33rd Annual Hawaii International Conference on System Sciences*, IEEE Computer Society Press, Los Alamitos, CA, 2000.
- [18] Moeltner, K., D.F. Layton, "A Censored Random Coefficients Model for Pooled Survey Data with Application to the Estimation of Power Outage Costs," *Review of Economics and Statistics* 84(2002):552–561.
- [19] Murillo-Sanchez, C.E., R.J. Thomas, "Thermal Unit Commitment including Optimal AC Power Flow Constraints," *Proceedings of the 31st Hawaii International Conference on System Sciences*, Kohala Coast, Hawaii, 1998.
- [20] Rassenti, S.P., V.L. Smith[[*also showed Wilson in the citation*]], 1998, "Deregulating Electric Power: Market Design Issues and Experiments," *Designing Competitive Electricity Markets*, H.P. Chao, H. Huntington, eds., pp. 105–120, Boston MA: Kluwer Academic Publishers, 1998.
- [20] Siegel, S., & Goldstein, D. A. (1959). Decision making behavior in a two choice uncertain outcome situation. *Journal of Experimental Psychology*, 57, 37-42.
- [21] Singh, H., S. Hao, A. Papalexopoulos, "Power Auctions and Network Constraints," *Proceedings of the 30th Hawaii International Conference on System Sciences*, Wailea, Hawaii, 1997.
- [22] Sullivan, M.J., B.N. Suddeth, T. Vardell, A. Vojdani, "Interruption Costs, Customer Satisfaction and Expectations for Service Reliability," *IEEE Transactions on Power Systems* 11(1996):989–995.
- [23] Taylor, C.W, "Power System Voltage Stability", Mc Graw Hill International Edition, Electrical Engineering Series, 1994
- [23] D. Toomey, W. Schulze, R. Schuler, R. Thomas, "Reliability, Electric Power, and Public Versus Private Goods: A New Look at the Role of Markets," *Proceedings of the 38th Hawaii International Conference on System Sciences*, 2005.
- [23] Wacker, G., R.K. Subramaniam, R. Billington, "Using Cost of Electric Service Interruption Surveys in the Determination of a Composite Customer Damage Function," *International Journal of Energy Systems* 5(1985):100–104.
- [24] Wolfram, C., "Measuring Duopoly Power in the British Electricity Spot Market." *American Economic Review* 89(1999):805–826.
- [25] Woo, C., R.L. Pupp, "Costs of Service Disruptions to Electricity Consumers," *Energy* 17(1992):109–126.
- [26] Woo, C., R.L. Pupp, T. Flaim, R. Mango, "How Much Do Electric Customers Want to Pay for Reliability? New Evidence on an Old Controversy," *Energy Systems and Policy* 15(1991):145–159.

- [27] Zimmerman, R. Thomas, D. Gan, C. Murillo-Sanchez “A Web-Based Platform for Experimental Investigation of Electric Power Auctions”, R., *Decision Support Systems*, vol. 24, no. 3&4, January 1999, pp. 193-205

Appendix A: Mathematical Details of the Model

List of Variables and Parameters with Simulation Parameter Values:

Note: 100 MVA is the base for per-unit (pu) values.

Note: A superscript on a variable denotes the corresponding state of that variable.

a = the multiplier for the intercept of each generator's capability curve.

- 17/30 pu-MVAr/pu-MW of capacity

$B_i(.)$ = the benefits at bus i from real-power consumption (measured in dollars).

- $B_1^{non-peak}(L) = -1,415,000(2.65L - 0.3)^4 + 1,000,000L$
- $B_2^{non-peak}(L) = -708,000(5.3L - 0.3)^4 + 1,000,000L$
- $B_3^{non-peak}(L) = -708,000(5.3L - 0.3)^4 + 1,000,000L$
- $B_4^{non-peak}(L) = -2,119,000(1.77L - 0.3)^4 + 1,000,000L$
- $B_1^{peak}(L) = -2,119,000(1.77L - 0.3)^4 + 1,000,000L$
- $B_2^{peak}(L) = -1,062,000(3.53L - 0.3)^4 + 1,000,000L$
- $B_3^{peak}(L) = -1,062,000(3.53L - 0.3)^4 + 1,000,000L$
- $B_4^{peak}(L) = -3,178,000(1.18L - 0.3)^4 + 1,000,000L$

b = the slope (in absolute value terms) of the capability curves.

- 0.5 pu-MVAr/pu-MW

c_G = the cost of producing each unit of real power.

- \$3300/pu-MWh

c_l = the cost of local delivery.

- \$5000/pu-MWh

c_Y = the per-period capital cost constant associated with building the lines.

- \$8.30/hour

c_M = the per-period capital cost of the inductors.

- \$6/pu-MVAr/hour

c_Z = the per-period capital cost of the capacity of each local generator.

- \$1000/pu-MW/hour

c_α = the per-period capital cost of the capacitors.

- \$1.50/pu-MVAr/hour

$D_i(.)$ = the damages faced at bus i from deviations in the voltage level (measured in dollars).

- $D_1^{non-peak}(\Delta V) = 40(20 \cdot \Delta V)^4$
- $D_2^{non-peak}(\Delta V) = 20(20 \cdot \Delta V)^4$
- $D_3^{non-peak}(\Delta V) = 20(20 \cdot \Delta V)^4$
- $D_4^{non-peak}(\Delta V) = 60(20 \cdot \Delta V)^4$
- $D_1^{peak}(\Delta V) = 60(20 \cdot \Delta V)^4$
- $D_2^{peak}(\Delta V) = 30(20 \cdot \Delta V)^4$
- $D_3^{peak}(\Delta V) = 30(20 \cdot \Delta V)^4$
- $D_4^{peak}(\Delta V) = 90(20 \cdot \Delta V)^4$

f_i = the failure indicator for the line segments between bus i and bus $i+1$. (A value of one indicates no failure and a value of one half indicates failure in one of the two segments).

G = the total real-power production by the generators (measured in pu-MW).

i = the index for busses.

I = the total number of busses.

L_i = the load at bus i (i.e., real-power consumption) (measured in pu-MW).

m = the minimum generation multiplier (indicates a percentage of available capacity that must be used).

- 25%

M_i = the quantity of inductors installed at bus i (measured in pu-MVAr).

N = the number of generators that are available in a given state (i.e., that have not failed).

Q_+ = the total positive VAr production by the generators (measured in pu-MVAr).

Q_- = the total negative VAr production by the generators (measured in pu-MVAr).

s = the index for states.

V_i = the voltage level at bus i .

V_0 = the standard voltage level.

- 1

Y = the admittance of each pair of line segments.

Z = the size (capacity) of each generator (measured in pu-MW).

α_i = the quantity of capacitors installed at bus i (measured in pu-MVAr).

γ = the load factor for the electricity buyers.

- 0.15 pu-MVAr/pu-MW

θ_i = the phase angle at bus i .

ρ_s = the probability of state s .

- The probability of the base state: 0.881736
- The probability of exactly one generator failing: 0.110592
- The probability of exactly two generators failing: 0.004608
- The probability of each line failure state: 0.001
- The probability of peak load: 0.5 (note that this probability crosses the ones listed above)

Lagrange multipliers, their associated constraints, and interpretations:

Note: A superscript on a multiplier denotes the corresponding state of that multiplier.

λ_i : the market-clearing constraint at bus i (the price of real power at bus i).

ν_i : the constraint limiting positive VAr use at bus i (the price of positive VARs at bus i).

τ_i : the constraint limiting negative VAr use at bus i (the price of negative VARs at bus i).

β_{min} : the minimum real-power production constraint.

β_{max} : the maximum real-power production constraint.

μ : the VAr production constraint for the generators (the generators' internal price of VARs).

η : the constraint that prevents generator VAr production from being both positive and negative.

The Theoretical Model

The social optimum for the model can be found by solving

$$(1) \max_{\{\alpha_i, M_i, Z, L_i^s, V_i^s, \theta_i^s, G^s, Q_+^s, Q_-^s\}} \sum_s \rho_s \left\{ \sum_i B_i^s(L_i^s) - c_G G^s - \sum_i D_i^s(V_i^s - V_0) - c_l \sum_i L_i^s \right\} \\ - \sum_i c_\alpha \alpha_i - \sum_i c_M M_i - 3c_Z Z - \sum_{i=1}^{I-1} c_Y Y^2$$

subject to the constraints that clear the markets for real power:

$$(2) G^s - L_1^s - f_1^s Y V_1^s V_2^s \sin(\theta_1^s - \theta_2^s) = 0 \quad \forall s \ i=1$$

$$(2') f_{i-1}^s Y V_{i-1}^s V_i^s \sin(\theta_{i-1}^s - \theta_i^s) - L_i^s - f_i^s Y V_i^s V_{i+1}^s \sin(\theta_i^s - \theta_{i+1}^s) = 0 \quad \forall s \ i=2, \dots, I-1$$

$$(2'') f_{I-1}^s Y V_{I-1}^s V_I^s \sin(\theta_{I-1}^s - \theta_I^s) - L_I^s = 0 \quad \forall s \ i=I,$$

with associated Lagrange multipliers λ_i^s ; the constraints that limit positive reactive-power use at each bus,

$$(3) \alpha_1 V_1^{s^2} + Q_+^s - Q_-^s - \gamma L_1^s - f_1^s Y V_1^{s^2} + f_1^s Y V_1^s V_2^s \cos(\theta_2^s - \theta_1^s) \geq 0 \quad \forall s \ i=1$$

$$(3') \alpha_i V_i^{s^2} - f_{i-1}^s Y V_i^{s^2} + f_{i-1}^s Y V_{i-1}^s V_i^s \cos(\theta_{i-1}^s - \theta_i^s) - \gamma L_i^s - f_i^s Y V_i^{s^2} \\ + f_i^s Y V_i^s V_{i+1}^s \cos(\theta_{i+1}^s - \theta_i^s) \geq 0 \quad \forall s \ i=2, \dots, I-1$$

$$(3'') \alpha_l V_l^{s2} - f_{l-1}^s Y V_l^{s2} + f_{l-1}^s Y V_{l-1}^s V_l^s \cos(\theta_{l-1}^s - \theta_l^s) - \gamma L_l^s \geq 0 \quad \forall s \quad i=l,$$

with multipliers ν_i^s ; the constraints that limit negative reactive-power use at each bus,

$$(4) \gamma L_1^s + M_1 V_1^{s2} - Q_+^s + Q_-^s + f_1^s Y V_1^{s2} - f_1^s Y V_1^s V_2^s \cos(\theta_2^s - \theta_1^s) \geq 0 \quad \forall s \quad i=1$$

$$(4') \gamma L_i^s + M_i V_i^{s2} + f_{i-1}^s Y V_i^{s2} - f_{i-1}^s Y V_{i-1}^s V_i^s \cos(\theta_{i-1}^s - \theta_i^s) + f_i^s Y V_i^{s2} - f_i^s Y V_i^s V_{i+1}^s \cos(\theta_{i+1}^s - \theta_i^s) \geq 0 \quad \forall s \quad i=2, \dots, I-1$$

$$(4'') \gamma L_l^s + M_l V_l^{s2} + f_{l-1}^s Y V_l^{s2} - f_{l-1}^s Y V_{l-1}^s V_l^s \cos(\theta_{l-1}^s - \theta_l^s) \geq 0 \quad \forall s \quad i=I,$$

with multipliers τ_i^s ; the constraint that the generators cannot be producing less than their minimum settings,

$$(5) G^s - N^s mZ \geq 0 \quad \forall s,$$

with multipliers β_{\min}^s ; the constraint that the generators cannot be producing more than their maximum settings,

$$(6) N^s Z - G^s \geq 0 \quad \forall s,$$

with multipliers β_{\max}^s ; the constraint limiting the production of reactive power by the generators,

$$(7) N^s aZ - bG^s - Q_+^s - Q_-^s \geq 0 \quad \forall s,$$

with multipliers μ^s ; and the constraint that requires at least one of Q_+^s and Q_-^s to be zero,

$$(8) Q_+^s Q_-^s = 0 \quad \forall s,$$

with multipliers η^s .

The first-order conditions will then be with respect to L_i^s ,

$$(9) \rho_s B_i^s (L_i^s) - \rho_s c_l - \lambda_i^s - \gamma \nu_i^s + \gamma \tau_i^s \leq 0;$$

with respect to G^s ,

$$(10) -\rho_s c_G + \lambda_1^s + \beta_{\min}^s - \beta_{\max}^s - b\mu^s \leq 0;$$

with respect to Q_+^s ,

$$(11) \nu_1^s - \tau_1^s - \mu^s + \eta^s Q_-^s \leq 0;$$

with respect to Q_-^s ,

$$(12) -\nu_1^s + \tau_1^s - \mu^s + \eta^s Q_+^s \leq 0;$$

with respect to V_i^s ,

$$(13) -\rho_s D_1^s (V_1^s - V_0) - \lambda_1^s f_1^s Y V_2^s \sin(\theta_1^s - \theta_2^s) + \lambda_2^s f_1^s Y V_2^s \sin(\theta_1^s - \theta_2^s) + \nu_1^s [2\alpha_1 V_1^s - 2f_1^s Y V_1^s + f_1^s Y V_2^s \cos(\theta_2^s - \theta_1^s)] + \nu_2^s f_1^s Y V_2^s \cos(\theta_1^s - \theta_2^s)$$

$$\begin{aligned}
& + \tau_i^s [2M_i V_i^s + 2f_i^s YV_i^s - f_i^s YV_{i+1}^s \cos(\theta_i^s - \theta_{i+1}^s)] - \tau_{i-1}^s f_{i-1}^s YV_{i-1}^s \cos(\theta_{i-1}^s - \theta_i^s) \leq 0 \quad i=1, \\
(13') \quad & - \rho_s D_i^s (V_i^s - V_0) - \lambda_{i-1}^s f_{i-1}^s YV_{i-1}^s \sin(\theta_{i-1}^s - \theta_i^s) + \lambda_i^s f_i^s YV_i^s \sin(\theta_{i-1}^s - \theta_i^s) \\
& - \lambda_i^s f_i^s YV_{i+1}^s \sin(\theta_i^s - \theta_{i+1}^s) + \lambda_{i+1}^s f_{i+1}^s YV_{i+1}^s \sin(\theta_i^s - \theta_{i+1}^s) + v_{i-1}^s f_{i-1}^s YV_{i-1}^s \cos(\theta_i^s - \theta_{i-1}^s) \\
& + v_i^s [2\alpha_i V_i^s - 2f_{i-1}^s YV_i^s + f_{i-1}^s YV_{i-1}^s \cos(\theta_{i-1}^s - \theta_i^s) - 2f_i^s YV_i^s + f_i^s YV_{i+1}^s \cos(\theta_{i+1}^s - \theta_i^s)] \\
& + v_{i+1}^s f_{i+1}^s YV_{i+1}^s \cos(\theta_i^s - \theta_{i+1}^s) - \tau_{i-1}^s f_{i-1}^s YV_{i-1}^s \cos(\theta_i^s - \theta_{i-1}^s) + \tau_i^s [2M_i V_i^s + 2f_{i-1}^s YV_i^s \\
& - f_{i-1}^s YV_{i-1}^s \cos(\theta_{i-1}^s - \theta_i^s) + 2f_i^s YV_i^s - f_i^s YV_{i+1}^s \cos(\theta_{i+1}^s - \theta_i^s)] - \tau_{i+1}^s f_{i+1}^s YV_{i+1}^s \cos(\theta_i^s - \theta_{i+1}^s) \leq 0 \\
& i=2, \dots, I-1,
\end{aligned}$$

$$\begin{aligned}
(13'') \quad & - \rho_s D_I^s (V_I^s - V_0) - \lambda_{I-1}^s f_{I-1}^s YV_{I-1}^s \sin(\theta_{I-1}^s - \theta_I^s) + \lambda_I^s f_I^s YV_I^s \sin(\theta_{I-1}^s - \theta_I^s) \\
& + v_{I-1}^s f_{I-1}^s YV_{I-1}^s \cos(\theta_I^s - \theta_{I-1}^s) + v_I^s [2\alpha_I V_I^s - 2f_{I-1}^s YV_I^s + f_{I-1}^s YV_{I-1}^s \cos(\theta_{I-1}^s - \theta_I^s)] \\
& - \tau_{I-1}^s f_{I-1}^s YV_{I-1}^s \cos(\theta_I^s - \theta_{I-1}^s) + \tau_I^s [2M_I V_I^s + 2f_{I-1}^s YV_I^s - f_{I-1}^s YV_{I-1}^s \cos(\theta_{I-1}^s - \theta_I^s)] \leq 0 \\
& i=I;
\end{aligned}$$

with respect to θ_i^s ,

$$\begin{aligned}
(14) \quad & - \lambda_1^s f_1^s YV_1^s V_2^s \cos(\theta_1^s - \theta_2^s) + \lambda_2^s f_2^s YV_2^s V_2^s \cos(\theta_1^s - \theta_2^s) + v_1^s f_1^s YV_1^s V_2^s \sin(\theta_2^s - \theta_1^s) \\
& - v_2^s f_2^s YV_2^s V_2^s \sin(\theta_1^s - \theta_2^s) - \tau_1^s f_1^s YV_1^s V_2^s \sin(\theta_2^s - \theta_1^s) + \tau_2^s f_2^s YV_2^s V_2^s \sin(\theta_1^s - \theta_2^s) \leq 0 \\
& i=1,
\end{aligned}$$

$$\begin{aligned}
(14') \quad & \lambda_{i-1}^s f_{i-1}^s YV_{i-1}^s V_i^s \cos(\theta_{i-1}^s - \theta_i^s) - \lambda_i^s f_i^s YV_i^s V_i^s \cos(\theta_{i-1}^s - \theta_i^s) \\
& - \lambda_i^s f_i^s YV_{i+1}^s V_{i+1}^s \cos(\theta_i^s - \theta_{i+1}^s) + \lambda_{i+1}^s f_{i+1}^s YV_{i+1}^s V_{i+1}^s \cos(\theta_i^s - \theta_{i+1}^s) \\
& - v_{i-1}^s f_{i-1}^s YV_{i-1}^s V_i^s \sin(\theta_i^s - \theta_{i-1}^s) + v_i^s f_i^s YV_i^s V_i^s \sin(\theta_{i-1}^s - \theta_i^s) \\
& + v_{i+1}^s f_{i+1}^s YV_{i+1}^s V_{i+1}^s \sin(\theta_{i+1}^s - \theta_i^s) - v_{i+1}^s f_{i+1}^s YV_{i+1}^s V_{i+1}^s \sin(\theta_i^s - \theta_{i+1}^s) \\
& + \tau_{i-1}^s f_{i-1}^s YV_{i-1}^s V_i^s \sin(\theta_i^s - \theta_{i-1}^s) - \tau_i^s f_i^s YV_i^s V_i^s \sin(\theta_{i-1}^s - \theta_i^s) \\
& - \tau_i^s f_i^s YV_{i+1}^s V_{i+1}^s \sin(\theta_{i+1}^s - \theta_i^s) + \tau_{i+1}^s f_{i+1}^s YV_{i+1}^s V_{i+1}^s \sin(\theta_i^s - \theta_{i+1}^s) \leq 0 \quad i=2, \dots, I-1,
\end{aligned}$$

$$\begin{aligned}
(14'') \quad & \lambda_{I-1}^s f_{I-1}^s YV_{I-1}^s V_I^s \cos(\theta_{I-1}^s - \theta_I^s) - \lambda_I^s f_I^s YV_I^s V_I^s \cos(\theta_{I-1}^s - \theta_I^s) \\
& - v_{I-1}^s f_{I-1}^s YV_{I-1}^s V_I^s \sin(\theta_I^s - \theta_{I-1}^s) + v_I^s f_I^s YV_I^s V_I^s \sin(\theta_{I-1}^s - \theta_I^s) \\
& + \tau_{I-1}^s f_{I-1}^s YV_{I-1}^s V_I^s \sin(\theta_I^s - \theta_{I-1}^s) - \tau_I^s f_I^s YV_I^s V_I^s \sin(\theta_{I-1}^s - \theta_I^s) \leq 0 \quad i=I;
\end{aligned}$$

with respect to α_i ,

$$(15) \quad -c_\alpha + \sum_s v_i^s V_i^{s^2} \leq 0;$$

with respect to M_i ,

$$(16) -c_M + \sum_s \tau_i^s V_i^{s^2} \leq 0;$$

with respect to Z ,

$$(17) -3c_Z - \sum_s \beta_{\min}^s N^s m + \sum_s \beta_{\max}^s N^s + \sum_s \mu^s N^s a \leq 0;$$

and with respect to Y ,

$$(18) - \sum_{i=1}^{l-1} 2c_Y Y - \sum_s \sum_{i=1}^{l-1} \lambda_i^s f_i^s V_i^s V_{i+1}^s \sin(\theta_i^s - \theta_{i+1}^s) + \sum_s \sum_{i=2}^l \lambda_i^s f_{i-1}^s V_{i-1}^s V_i^s \sin(\theta_{i-1}^s - \theta_i^s)$$

$$+ \sum_s \sum_{i=1}^{l-1} v_i^s \left[f_i^s V_i^s V_{i+1}^s \cos(\theta_{i+1}^s - \theta_i^s) - f_i^s V_i^{s^2} \right]$$

$$+ \sum_s \sum_{i=2}^l v_i^s \left[f_{i-1}^s V_{i-1}^s V_i^s \cos(\theta_{i-1}^s - \theta_i^s) - f_{i-1}^s V_i^{s^2} \right]$$

$$+ \sum_s \sum_{i=1}^{l-1} \tau_i^s \left[f_i^s V_i^{s^2} - f_i^s V_i^s V_{i+1}^s \cos(\theta_{i+1}^s - \theta_i^s) \right]$$

$$+ \sum_s \sum_{i=2}^l \tau_i^s \left[f_{i-1}^s V_i^{s^2} - f_{i-1}^s V_{i-1}^s V_i^s \cos(\theta_{i-1}^s - \theta_i^s) \right].$$

Appendix B: Simulation Results

Probabilities of States:	
Base (Peak)	0.4409
1 gen down	0.0553
2 gens down	0.0023
Line 1 down	0.0005
Line 2 down	0.0005
Line 3 down	0.0005
Base (Non-Peak)	0.4409
1 gen down	0.0553
2 gens down	0.0023
Line 1 down	0.0005
Line 2 down	0.0005
Line 3 down	0.0005

Load (MW):	Bus 1	Bus 2	Bus 3	Bus 4	Voltage:	Bus 1	Bus 2	Bus 3	Bus 4
Base (Peak)	39.793	19.954	19.954	59.689	Base (Peak)	1.012	1.018	1.017	1.007
1 gen down	39.793	19.954	19.954	59.689	1 gen down	1.012	1.018	1.017	1.007
2 gens down	24.506	12.288	12.288	36.760	2 gens down	0.998	1.002	1.001	1.000
Line 1 down	39.793	19.274	18.915	55.342	Line 1 down	1.153	1.208	1.153	1.107
Line 2 down	39.793	19.747	19.312	57.072	Line 2 down	1.111	1.177	1.149	1.101
Line 3 down	39.793	19.824	19.698	58.088	Line 3 down	1.092	1.138	1.143	1.086
Base (Non-Peak)	26.580	13.288	13.288	39.793	Base (Non-Peak)	1.000	1.000	1.000	1.000
1 gen down	26.580	13.288	13.288	39.793	1 gen down	0.999	0.999	0.999	1.000
2 gens down	24.548	12.272	12.272	36.751	2 gens down	0.998	1.002	1.002	1.001
Line 1 down	26.580	13.288	13.288	39.793	Line 1 down	1.000	1.001	0.999	1.000
Line 2 down	26.580	13.288	13.288	39.793	Line 2 down	1.001	1.003	1.003	1.001
Line 3 down	26.580	13.288	13.288	39.793	Line 3 down	0.999	1.000	1.003	0.998
Price per MW:	Bus 1	Bus 2	Bus 3	Bus 4	Price per MVar:	Bus 1	Bus 2	Bus 3	Bus 4
Base (Peak)	\$83.00	\$83.60	\$84.20	\$84.79	Base (Peak)	\$0.00	\$0.00	\$0.00	\$0.03
1 gen down	\$83.00	\$83.60	\$84.20	\$84.79	1 gen down	\$0.00	\$0.00	\$0.00	\$0.03
2 gens down	\$9,640.96	\$9,640.96	\$9,640.96	\$9,640.96	2 gens down	\$0.00	\$0.00	\$0.00	\$0.00
Line 1 down	\$83.00	\$1,746.86	\$2,545.21	\$3,407.99	Line 1 down	\$0.00	\$6.61	\$0.00	-\$55.40
Line 2 down	\$83.00	\$611.02	\$1,657.45	\$2,194.15	Line 2 down	\$0.00	\$13.52	\$21.45	-\$43.01
Line 3 down	\$83.00	\$417.71	\$735.41	\$1,410.52	Line 3 down	\$0.00	\$0.00	\$0.00	\$0.00
Base (Non-Peak)	\$82.99	\$82.99	\$82.99	\$82.99	Base (Non-Peak)	\$0.00	\$0.00	\$0.00	\$0.00
1 gen down	\$83.01	\$83.01	\$83.01	\$83.01	1 gen down	\$0.00	\$0.00	\$0.00	\$0.00
2 gens down	\$3,540.81	\$3,540.81	\$3,540.81	\$3,540.81	2 gens down	\$0.00	\$0.00	\$0.00	\$0.00
Line 1 down	\$83.00	\$83.00	\$83.00	\$83.00	Line 1 down	\$0.00	\$0.00	\$0.00	\$0.00
Line 2 down	\$83.00	\$82.99	\$82.99	\$82.99	Line 2 down	\$0.00	\$0.00	\$0.00	\$0.00
Line 3 down	\$83.00	\$83.00	\$83.00	\$83.00	Line 3 down	\$0.00	\$0.00	\$0.00	\$0.00
Capac/Ind Prod'n (pu-MVAr):	Bus 1	Bus 2	Bus 3	Bus 4	Angle Difference (Degrees):	1 and 2	2 and 3	3 and 4	SUM
Base (Peak)	0.006	0.239	0.180	0.085	Base (Peak)	12.541	9.945	7.513	30.000
1 gen down	0.005	0.239	0.180	0.085	1 gen down	12.541	9.945	7.513	30.000
2 gens down	0.006	0.111	0.058	0.066	2 gens down	7.909	6.303	4.731	18.944
Line 1 down	0.000	0.662	0.056	-0.118	Line 1 down	17.547	6.870	5.583	30.000
Line 2 down	0.003	0.628	0.325	-0.117	Line 2 down	9.496	14.693	5.812	30.000
Line 3 down	0.005	0.377	0.314	0.010	Line 3 down	10.154	7.715	12.132	30.000
Base (Non-Peak)	0.005	0.103	0.067	0.078	Base (Non-Peak)	8.562	6.842	5.126	20.530
1 gen down	0.006	0.100	0.065	0.082	1 gen down	8.587	6.860	5.133	20.580
2 gens down	0.006	0.101	0.067	0.067	2 gens down	7.912	6.293	4.714	18.918
Line 1 down	0.004	0.161	0.060	0.081	Line 1 down	17.332	6.844	5.129	29.305
Line 2 down	0.005	0.140	0.109	0.070	Line 2 down	8.533	13.709	5.105	27.347
Line 3 down	0.005	0.093	0.112	0.084	Line 3 down	8.568	6.817	10.278	25.663