

“Two-Sided Electricity Markets: Self-Healing Systems”

by

Richard E. Schuler*, P.E., Ph.D.
Prof. of Economics
Prof. of Civil and Environmental Engineering
Cornell University
Ithaca, NY 14853

Final Draft: October 26, 2005

Paper Originally Presented at 2005 CREATE Workshop
August 19-20, Los Angeles, CA

Abstract

High voltage electricity systems may become more reliable under market-based dispatch than they were under cost-based, regulated assignments if customers are faced with real-time prices. As an example, in Australia where all electricity is transacted through a spot energy market without any regulatory price caps, retail suppliers and large customers have installed frequency-sensing devices to turn off or reduce power to designated loads when the system's frequency falls below a pre-set level. While most of these relay installations were required by the grid managers, some of the automated load-shedding is also purchased as a market service. These mechanisms were put to the test in summer 2004 when the system suddenly lost 3,100 MW of generation. Sufficient load was shed automatically so the system re-stabilized within 30 seconds. In periods when demand exceeds the system's supply capability, either because of unexpected high demand or supply disturbances, there is an inverse relationship between frequency and the price of electricity. So automatic load-shedding devices could also help buyers avoid price spikes.

While there is little experience in the United States with widespread direct customer participation in electricity markets, economic experiments have been conducted at Cornell University with human subjects. These trials of full two-sided electricity markets are cleared subject to the laws of physics over Cornell's PowerWeb, 30 bus, 6 generator, simulated A.C. power network. The results demonstrate the ability of a small portion (20 percent) of active customers to mute the market-power exercised by sophisticated players representing the generators, all without regulated price caps or strictures against withholding capacity. Furthermore, simulations of electrical flows on individual lines suggest that the capacity needs of the system per MW of overall demand are up to ten percent smaller with active customer participation, compared to a regulated regime, and that would provide more breathing room for existing facilities. Those line flows are also more predictable when customers are actively engaged in power markets, making the job of dispatching and controlling the system easier. So if we want to reap the full benefits of markets for power in the U.S., including enhanced reliability and robust rapid responses to natural or terrorist inflicted assault, we need to get the customers into the game as full participants.

* Work on this analysis was supported through NYU by the Center for Risk and Economic Analysis of Terrorism Events, funded by the U.S. Department of Homeland Security at the University of Southern California. I am grateful to the continued collaboration by my colleagues and students at Cornell University who worked with me on many of the analyses contained in this paper. They include Nodir Adilov, Tom Light, Tim Mount, Bill Schulze, David Toomey, Bob Thomas, Jim Thorp and Ray Zimmerman. I would also like to express appreciation for support on related projects provided by the Power Systems Engineering Research Center (PSERC), an NSF-supported industrial consortium, and the Consortium for Electricity Reliability Technology Solutions (CERTS), funded by the U.S. Department of Energy.

I. Introduction

Active customer participation in electricity markets, particularly charging buyers for the real-time actual cost of supplying their needs, may lead to a far more reliable system at lower cost than under current practice in the U.S. In effect, we still have a socialist system of supply that shields customers from the true cost consequences of their purchasing choices. Because like low gasoline prices, the reliable low-cost supply of electricity that is always available on instantaneous demand has become an entitlement for most consumers, it has been extremely difficult politically to institute true real-time retail markets for electricity, even though wholesale markets have been deregulated in many regions of the country for over five years. But since there exists an inverse relationship between system reliability conditions and the real time price of electricity, raising each and every customer's awareness of those periodic stresses may not only save customers money, on average, it may also increase the system's resilience to insults - - both natural and terrorist-induced.

Much of the focus on terrorist attacks on the power grid imagines widespread areas of the country without electricity like during the northeast blackout of August 15, 2003. However, as outlined in a recent CREATE report (Zimmerman, et. al., 2005 [9]), unless prolonged over many days, the social impact of massive regional outages is small. Rather it is extended widespread local outages that result from numerous physical breaks in the local electricity distribution system, each of which must be repaired individually, that can lead to substantial human harm. Examples are the consequences of hurricanes or ice-storms that can leave many customers in areas larger than a state without electricity for more than a week simply because there are not enough trained repair crews to restore the multitude of widespread downed lines more rapidly. By contrast, in most instances a multi-state regional blackout is usually precipitated by only one or two actual physical faults on the system that trigger wild swings in power flows (dynamic instabilities). Here a design aspect of the system, to preserve as much of the equipment on the high-voltage power grid from harm as possible, leads to the automatic isolation of supply equipment so that the system might be restored again rapidly after the outage without requiring the repair of many damaged pieces of equipment (see Schuler, 2005 [5] for a detailed discussion of this design and operating philosophy). So while a sudden widespread regional blackout receives most of the headlines, it is only if coupled with the simultaneous physical damage of geographically dispersed supply equipment that the blackout might become prolonged. Historically, that widespread failure of equipment has not been the initiator of the blackout. Instead it has been the disconnection and isolation of equipment as a conscious automated protection strategy that when triggered in response to some large initial failure, expands the blackout but also paves the way for a speedy restoration - - usually within a day.

If the rapid disconnection of crucial pieces of supply equipment is important for their physical protection, then in these highly unstable transient periods, it would also be helpful to have the users respond nearly as rapidly, since electricity cannot be stored and supply must closely approximate demand in every instant. Thus having load respond automatically to match the automated equipment disconnects might preserve and sustain electric service in many portions of the region that might otherwise be subject to a

widespread blackout - - if only customers could respond in time. Furthermore, because it is precisely because of shortages of generation supply that the cost of providing an additional kWh of electricity soars, confronting the buyers with those real-time prices might induce them to invest in equipment that might disconnect some of their equipment automatically, thus saving both money and the system.

II. An Example From Australia

On Friday August 13, 2004 a transformer short-circuited and eventually exploded in a power station leading to a sequence of automated responses that ultimately disconnected six generating units with a combined capacity of 3,100 MW (see NEEMCO Final Report, 2005 [4]). As a result, the system frequency fell below 49 Hertz (cycles per second), more than a two percent reduction from Australia's 50 Hertz norm. Sixty percent of this drop in supply occurred instantaneously: the other two units tripped off-line thirteen and twenty one seconds afterward, as shown in Figure 1. This figure illustrates the precipitous fall in frequency within five seconds following the separation of the first three generators, and subsequent frequency drops after the separation from the system of each of the other two units. In between other generation attempted to pick up some of the capacity deficit. However, in large part because the Australian system managers mandate that their load-serving entities (wholesale buyers) install frequency-sensing, automatic, load-shedding devices, 1500 MW of demand was available for automatic response, and another small portion of the loads had installed these devices in exchange for receiving payments for making this service available to the system. The net result, as illustrated in Figure 1., is that the system began to respond automatically to the initial disconnects within six seconds (far more rapidly than could have occurred in response to any human instructions), and within 31 seconds the system was on the path back to normal 50 Herz operation.

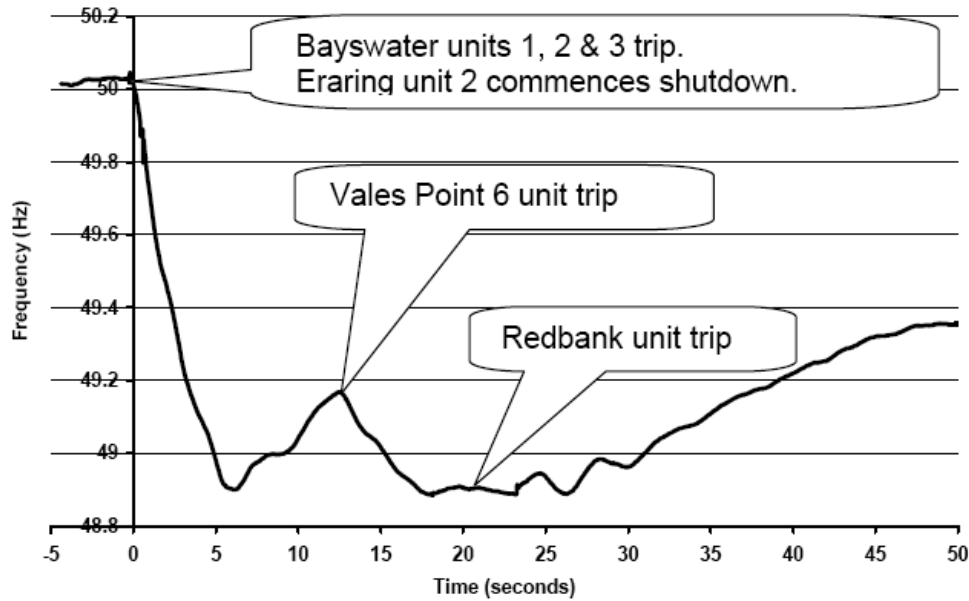

Figure 1. Australian Generation-Loss Experience: System Frequency Over Time (source [4])

Significant differences also exist in the wholesale market structures used in Australia, as compared to the U.S. There are only physical real time energy markets in Australia, and the price cap is set at \$14/ kWh, fourteen times higher than the largest price cap in the U.S. Thus customers are sensitive to shortage periods when the price of electricity can soar, and they therefore may be more willing to accept supply interruptions, particularly if those reductions can be channeled to less essential equipment. Furthermore, in a simulation of operations on a simple hypothetical power grid at Cornell University, Toomey et. al. [7] have demonstrated the relationship between system frequency (here 60 Herz is the norm in the U.S.) as an indicator of reliability and market price, as shown in Figure 2. Notice the inverse relationship between price and frequency. This suggests that load disconnect switches triggered by frequency-sensing detectors might be used by customers to mute the effect of price spikes on the system. At the same time, the customers' price-induced responses would help to maintain system reliability. However, the sum of those market-driven responses by individual customers cannot be counted on to achieve the overall socially optimal level of system reliability. Since all customers in a neighborhood are served from the same electricity line, they receive the identical protection from unanticipated interruptions - - a public good that is subject to free-riding - - regardless of the differences in preferences among them. So, additional regulatory intervention beyond the individual responses by customers to prices is required in order to achieve that socially optimal level of reliability.

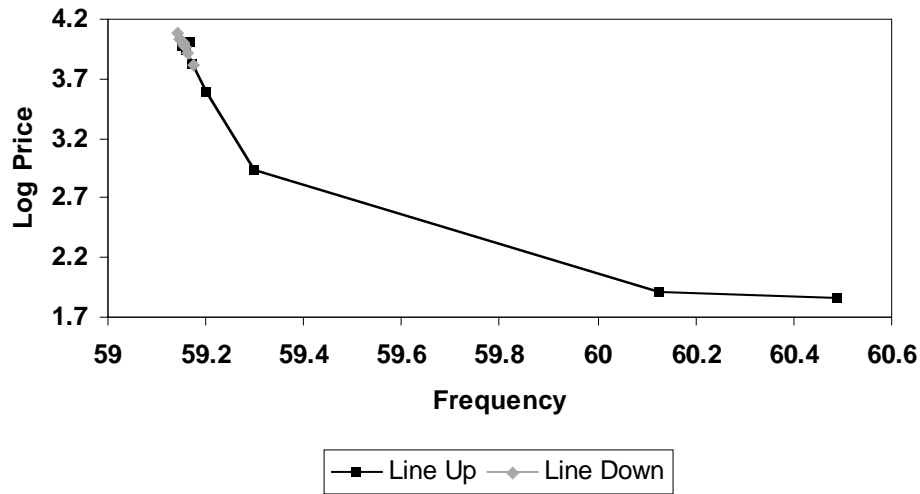

Figure 2. Relationship of Price to System Frequency in a Simple Three Bus Simulated Power System (source: [7])

III. Inferences from Laboratory Experiments

In fact there is virtually no experience in the U.S. with the operation of large power systems under market conditions where a substantial fraction of the customers participate actively in the real-time market, in large part because such practice is thought to be politically unacceptable. That is why a long series of experiments have been conducted at Cornell University with human participants creating buyer and seller behavior, but where the actual power flows are governed by the laws of physics. A simple 30 bus system with six generators is used to replicate an alternating current network, and the buyers and sellers are located throughout this system.

A wide range of experiments have been conducted to explore the efficiency of alternative market-clearing mechanisms, and/or the effect of the number of different suppliers on their ability to exercise market power by exploiting system congestion. Other experiments have explored the effects of markets for generation reserves by location in combination with energy and VARs markets. The following analysis draws heavily on these experiments by examining the consequences of alternative structures for two-sided markets with active demand-side participation [2]. The implications for system generation requirements and line capacities were reported earlier this year [1]. Thus this latest analysis should be instructive for inferring the implications that more active customer participation in real time markets may have for the system's ability to withstand insults.

These experiments tested the efficiency of two alternative forms of active demand-side

participation (See Adilov, et.al. [2]). As a base case for comparison, the typical utility pricing mechanism was tested where buyers pay a pre-determined fixed price (FP) in all periods. In the second treatment, buyers were alerted prior to consumption periods when supply shortages were anticipated. In those periods, customers were given the opportunity of reducing their consumption below their normal benchmark purchases in similar periods, and by doing so they were able to earn a pre-specified credit per kWh for each unit of reduced consumption. The third treatment was a simple real time pricing (RTP) scheme where price forecasts were announced for the next day and night periods, and based upon those forecasts, buyers decided how much electricity to purchase. However, buyers paid the actual market-clearing price in each period for their purchases, and that price usually differed slightly from the forecasted price.

In each of these experiments, suppliers were free to engage in whatever offering behavior they liked, short of collusion with their competitors. The original purpose of these experiments was to understand the extent to which electricity markets might become more self-regulating, economically, were widespread customer participation to become prevalent [2]. However, the supply and demand allocations from these previous experiments have also been used to explore the physical implications for design capacities, the extent to which electricity flows become more predictable as the customers achieve greater involvement, and therefore the implications for the cost of providing reliability [1].

A. Description of Prior Experimental Trials

Buyer Problem

Each buyer was assigned a simple two-step discrete demand function with separate valuations for day and for night usage, as shown in Figure 3. In fact, these individual demand relationships are decomposed from an aggregate demand function that has a retail price elasticity of demand, at the mean price, of -0.3 , Faruqui and George [3]. Nineteen different buyers were included in each experiment, each with different assigned valuations. The aggregate demand function, ranging from very low prices to the reservation price, was given the inverted S-shape suggested by Schulze's work (reported by Woo, et. al. [8]) on the loss in consumer value for interruptible service.

Each customer's valuation differs between day and night, and there is an additional "substitutable" block of energy that customers can choose to buy in either period (unused substitutable energy cannot, however, be carried over to the next day/night pair of periods). Typically, substitutable electricity purchases are valued less than the regular purchases in each of these periods. Furthermore, these induced valuations are increased substantially in pre-specified periods called "Heat-Waves" to reflect the added value of electricity in extreme climatic conditions. The buyer's problem then is to maximize the spread between their assigned valuation for each quantity of electricity they buy, and the price they have to pay for it. Thus if all consumers behave optimally in these experiments, the total system load should be grouped around four distinct levels, representing combinations of normal, heat wave, day and night periods.

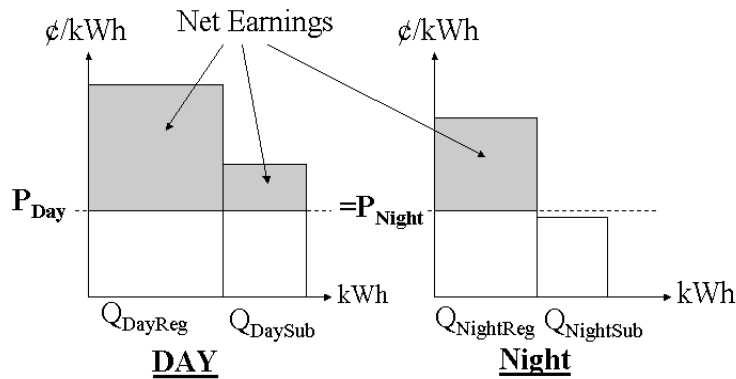

In this Example: $Q_{Day} = Q_{DayReg} + Q_{DaySub}$
 $Q_{Night} = Q_{NightReg} + 0$
 $Q_{DaySub} + Q_{NightSub} \leq Q_{SubMAX}$

Figure 3. Illustration of Buyer's Problem

Seller's Problem

Each of the six active suppliers was assigned three different generating units with different constant incremental production costs. In addition there was a fixed cost associated with each supplier's total capacity that was paid regardless of the supplier's level of activity. Each supplier is free to offer as much or little capacity into the market, up to the total capacity limit on their generation, as they wish, and they can specify a different price for each of the three different blocks of power. Offers may be made at prices lower or higher than the incremental production cost. The discretionary cost each supplier can incur is associated with whether or not and how much capacity they offer into the market. Each MW offered bears an opportunity cost of \$5.00, regardless of having been selected to generate. This opportunity cost represents the commitment of resources and/or cost of foregone maintenance that is associated with planning to have those units available, as reflected in making an offer. The seller's problem is illustrated in Figure 4, and since the market in each period clears at the highest offer needed to meet the market demand, all suppliers with offered prices at or below that level are paid the identical last (highest) accepted offer. Each seller earns a profit in each period equal to the market price times the quantity they sell, minus the incremental cost of generating the electricity they sell, minus the \$5.00 opportunity cost times all of the energy they offer into the market, minus their fixed costs.

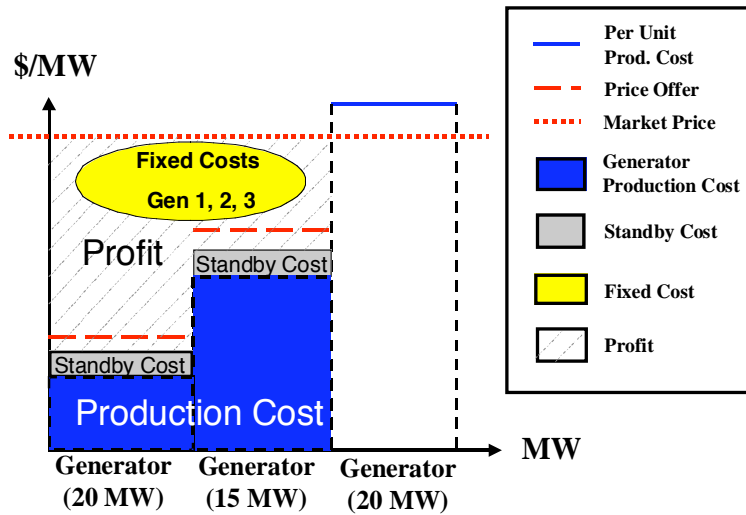

Figure 4. Illustration of Seller's Problem

Market Structure and Calibrations

In these two-sided markets, 19 buyers and 8 sellers were included. Six suppliers were represented by humans; the seventh seller was the only generator subject to random outages, and its behavior was simulated numerically so that none of the six active participants would feel that their earnings were biased by a random phenomenon. A computer-simulated agent with a single 30MW block of low-cost \$20/ MW generation was used to represent the outage unit and its capacity was always offered at \$25/MW (including the \$5/MW opportunity cost of making offers). The eighth supplier was a high-priced external source that was used only when internal supplies were not sufficient to clear the market

Each of the buyers was assigned a different set of valuations for the energy they could purchase, and for approximately 80 percent of the buyers, those values were set very high, but realistically, based upon previous empirical work (see Woo et. al. [8]). Therefore, the optimal quantity to be purchased did not change for the majority of buyers as prices varied unless the market-clearing prices reached levels many multiples higher than normally anticipated. Given the popular sentiment that most buyers are not interested in altering their electricity consumption or participating in demand side programs, this assignment of values reflects that assertion.

Each of the three demand-side treatments was tested over the identical eleven day-night pairs (22 periods, total) with the same sequence of combinations of normal periods, heat-waves and unit-outages. DRP was triggered by any predicted retail price that exceeded \$.106/kWh so that speculative behavior on the part of suppliers might also initiate this program. The average market demand in these experiments was designed to be approximately 200 MW (lower at night, higher during the day and in heat waves), and

330 MW of active supply was available, plus the 30 MW provided by the numerically-simulated base-load unit, when not subject to a random outage. The wholesale market was cleared at, and all accepted suppliers were paid, the uniform price of the highest (last) accepted offer. Demand was always met, despite withholding, because of the availability of purchases from external sources, about which all participants knew.

Market Sequence

Each market period began with the auctioneer (ISO/RTO) providing fair load forecasts (quantities) for the upcoming two (day-night pair) periods. All buyers and sellers were told before each day-night pair whether the upcoming period had normal or heat-wave conditions, and whether or not a unit outage had occurred. Next the suppliers submitted their price-quantity offers for both of the day-night periods. Then, either price forecasts or firm prices and/or anticipated market conditions were given to the buyers. Under FP, the retail price was always set at \$.085/kWh, which included a \$.04/kWh wires charge, regardless of wholesale market conditions. Under the DRP treatment, the same fixed price of \$.085/kWh was charged for all purchases, but when DRP was announced to be in effect, a \$.079/kWh credit for purchases below each buyer's announced benchmark consumption level was provided. Under the RTP treatment, a fair forecast of market clearing prices for the next day-night pair was announced, based upon market conditions and the suppliers' offers. The buyers then made their quantity purchases, suppliers were committed and the market clearing wholesale prices were declared. In the case of RTP, buyers were told the actual price they were assessed for their purchases in each of the previous day-night periods, which however didn't vary more than twenty percent from the forecast prices for those periods. Finally, each seller was told their earnings, and each buyer was apprised of the net value of their purchases, including DRP credits where applicable. The process was then repeated for the next day-night pair until all eleven pairs were completed.

B. Summary of Experimental Results for Two-Sided Markets

These experiments were repeated for two different groups of participants, and the resulting total market efficiencies are summarized in Table 1 for the DRP and RTP treatments as a percentage of the wholesale revenues under the FP treatment. As a benchmark, the theoretical socially optimal levels of efficiency are also presented. The combined data indicate that it is possible to gain 6.75 % in overall efficiency, compared to a FP system, without regulatory controls on suppliers. Experiments on both DRP and RTP also provide welfare gains to consumers, but in the case of DRP the offsetting loss to suppliers is so great that there is a net welfare loss; whereas with RTP, a combined gain of 2.02% is obtained. In many instances, the large price spikes generated under the FP system are muted by the RTP and DRP treatments, as shown elsewhere (see Adilov, et. al. [2]).

Most of the substantive differences in the quantities purchased between the different pricing schemes are statistically significant. As shown in Table 1, buyers consume less electricity in all periods under DRP, as compared to FP; whereas, under RTP customers

buy more electricity at night and less during the day than under FP. Furthermore, the last column emphasizes the overall conservation effect of DRP since it results in a statistically significant reduction in purchases both during the day and at night, as compared to RTP. Unfortunately, there is too much conservation under DRP, as highlighted by the separate quantity comparisons between both DRP and RTP and the socially optimal level of consumption where RTP results in the smallest difference.

Table 1. Two-Sided Experimental Results: Overall Efficiency for Combined Trials

1. Deviations as % of FP Revenues without Regulation:

	% Added <u>Consumer Value</u>	% Changes <u>Supplier Profit</u>	Combined <u>Change</u>
RTP	9.02	-6.99	2.02%
DRP	13.86	-17.52	-3.67%
Social Optimum (as comparison)	29.32	-22.57	6.75%

2. Statistically Valid Differences in Behavior from FP Results (@ .95 level):

	<u>RTP vs. FP</u>		<u>DRP vs. FP</u>	
	<u>Consumers</u>	<u>Sellers*</u>	<u>Consumers</u>	<u>Sellers*</u>
Value/Profit	+	-	+ ?	-
<u>Quantities Bought/Sold:</u>				
Days	-	- ?	-	-
Nights	+	+ ?	-	+ ?

*Note: With fewer sellers, statistical significance is harder to attain.

In a poll that was conducted for both groups of subjects that participated in this experiment, there was a reversal of stated preferences from selecting DRP to preferring RTP as experience was gained with both regimes. The first group switched from 74% preferring DRP initially to 64% preferring RTP afterward, a statistically significant reversal. The second group's reversal was less appreciable, moving from only 53% preferring DRP ahead of time to 68% preferring RTP after having tried both. However the final fraction that preferred RTP was similar in both groups.

C. Implications for Flows on Individual Lines

The market-clearing supply by each generator and the usage by each customer were assigned to specific nodes on the PowerWeb simulated thirty bus electrical network shown in Figure 3. The locations of generators remained fixed, but since the flows on individual lines differ depending on the demand characteristics at each bus, and the assigned valuations for electricity purchases varies widely among different participants, fifteen different randomly selected spatial allocations of the buyers were made for each of the two different sets of participants in the experimental trials. Since each trial was comprised of twenty two time periods (eleven day-night pairs), the period with the maximum line flow was selected as the surrogate for required installed capacity for each 22-period trial. In every case, the line flows were computed using an a.c., non-linear optimal power flow procedure to minimize the total cost of meeting the demand, and these maximum line flows are summarized in Table 2 by market treatment and customer

assignment.

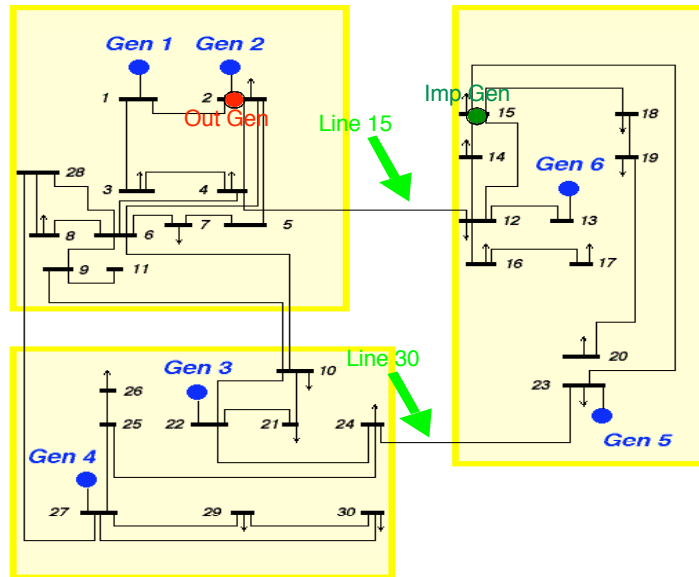

Figure 3. Power Web Simulated Electricity Network with Monitored Lines

In addition to the three market-based treatments (FP, DRP, and RTP), the line flows were computed for the socially optimal conditions (cost-based offers and optimal purchases by buyers), and the former regulatory regime was simulated under fixed-price purchases by buyers. In this simulation of regulation, the actual purchases by each customer under the FP market regime were used, but the supplies were replaced by a least-cost, cost-based allocation.

For each of the 30 trials (think: different power systems) the sum of maximum flows across all lines under RTP is smaller than for the regulated regime. This fact is highlighted in Table 2 by the pair-wise differences in this sum of maximum line flows. Under every system configuration, the difference between the sum of maximum line flows (SumMax) under regulation with FP and under markets with RTP is positive! Furthermore, Table 2 notes that across all system configurations, the SumMax for RTP averages 6.4 percent less than for the regulated regime, which is suggestive that on average less line capacity might be required under markets, if they are two-sided with active customer response. By comparison, SumMax averages .7 percent greater flows for market-based systems with FP than for regulated systems with the same FP signals to buyers. However, the market regime simulated here has no price caps or restrictions on capacity withholding, as compared with markets actually implemented in the U.S., so suppliers in these experiments are free to speculate wildly under the market regime; whereas the regulated regime is simulated with cost-based supplies throughout.

Table 2, also shows that the DRP demand-side mechanism is effective (as is RTP) in moderating speculative behavior by suppliers, since for every customer configuration the difference in SumMax between FP and DRP is positive (as it also is for FP-RTP), and

SumMax for DRP is also smaller than for the regulated regime in all but one of the thirty configurations. In fact, on average across all configurations, DRP results in an 8.7 percent smaller SumMax than for a regulated regime, suggesting how effective active demand side participation might be in moderating peak line flows, and in the long run in reducing investment in facilities.

The maximum system loads are also tabulated for each of these market regimes in Table 2 where RTP is shown to result in a 7.6 percent reduction in peak load, as compared with the regulated regime under FP (peak loads under regulation might also be lower if RTP were inaugurated under regulation, but that scenario cannot be fairly simulated with the available experimental data). Finally, note that the maximum flows are also computed for socially optimal power exchanges, and Table 2 indicates on average across all 30 system configurations, the RTP market system comes closest to this ideal, both in terms of the sum of maximum line flows across each system, and in terms of peak loads. In fact, t-tests were conducted on the pair-wise differences in SumMax across all combinations of regimes (where SumMax for each configuration is considered an observation). Both DRP and RTP simulations yield statistically significantly lower line flows than under a FP regulatory regime, and only the FP market regime results in slightly higher, but significant, line flows as compared to the FP regime under regulation (note: none of the simulations for the regulatory regime consider differences in unit costs that might arise because of different incentives).

Table 2. Implied Line and Generation Capacity Requirements by Market Treatment

Regime	FP	DRP	RTP	REG	SO
<i>Sum Across All Lines in the System of Maximum Absolute Value in Flow (MW)</i>					
<i>Across 22 Time Periods for Each of 39 Lines</i>					
Average All Trials 1-30	649.57	588.74	604.03	645.15	604.76
% Difference from REG	0.7%	-8.7%	-6.4%	0.0%	-6.3%
Avg. Difference from REG	4.42	(56.41)	(41.12)	-	(40.40)
Paired T-Statistic	2.32	(6.93)	(10.33)	-	(20.48)
P-Value	0.027	0.000	0.000	-	0.000
<i>Summary of System Load (MW)</i>					
Average System Load All Trials 1-30	178.58	158.56	172.43	178.58	176.14
% Difference from REG	0.0%	-11.2%	-3.4%	0.0%	-1.4%
Max System Load All Trials 1-30	275.00	275.00	254.01	275.00	252.00
% Difference from REG	0.0%	0.0%	-7.6%	0.0%	-8.4%

Table 3. Statistical Relation Between Line Flows and System Load

	Social Optimum	(Reg. Regime) Fixed Price with Regulated Sellers	Results with Active Participants		
			Fixed Price	Demand Reduction Program	Real Time Pricing
<i>Regression Results for Tie Line 15</i>					
Intercept	40.1779	39.1761	17.9780	29.9462	33.0568
Std Err	3.0375	2.1514	3.1385	3.8662	3.5013
Slope Coefficient	(0.1982)	(0.1901)	(0.1025)	(0.1789)	(0.1909)
Std Err	0.0167	0.0116	0.0168	0.0236	0.0197
R-Squared	0.7701	0.8657	0.4695	0.5777	0.6906
F-Statistic	140.6651	270.7614	37.1714	57.4517	93.7394
P-value	0.0000	0.0000	0.0000	0.0000	0.0000
<i>Regression Results for Tie Line 30</i>					
Intercept	(17.5262)	(18.5527)	(9.1573)	(13.9666)	(17.5818)
Std Err	1.5631	1.7259	2.4566	3.0202	3.1587
Slope Coefficient	0.0751	0.0753	0.0437	0.0802	0.1024
Std Err	0.0086	0.0093	0.0132	0.0184	0.0178
R-Squared	0.6449	0.6111	0.2079	0.3104	0.4409
F-Statistic	76.2617	66.0048	11.0260	18.9069	33.1193
P-value	0.0000	0.0000	0.0019	0.0001	0.0000
Note: The following linear regression equation was estimated with OLS.					
Line Power Flow = Bo + B1 x System Load					
N = 44 for all regressions					

D. Line Flow Predictability

In previous experimental analyses of the single-sided electricity markets (no active demand-side participation) used throughout the U.S., the simulated line flows are directly proportional to system load when the dispatch minimizes total system cost and is based upon the actual cost of generation (e.g. simulations of perfectly regulated or perfectly competitive markets). But, when that least-cost dispatch is based upon offers from deregulated suppliers who are free to speculate, that highly correlated simulation of physical relationship breaks down and is highly erratic (See Thomas [3]). Thus it is interesting to explore the physical line flows that might be inferred from these recent experiments on full two-sided markets with active demand-side participation. One indication of the facility with which the system might be operated under various market regimes is suggested by the relationship between overall system load and the flows on any individual line.

In a preliminary analysis using the line flows derived from the PowerWeb 30 bus electrical transmission network shown in Figure 3, two lines were selected to illustrate the possibilities. The location of all generators is shown, including the import generator that cleared the market when insufficient internal supplies were offered. Two of the lines were selected for analysis (line 15 with the greatest variability and the more typical line

30), but the flows for only one of the thirty random allocations of buyers to busses is used in this illustration. Statistical tests were performed on the correlation between system load and line flows on those two links for the different market regimes. These regression results are summarized in Table 3. Because of the location of the generators and specific buyers, there is actually a negative correlation between system load and the flow on line 15 (due to changes in the optimal system dispatch), but that negative relationship exists under all five regimes. What is different is the magnitude and the degree of statistical significance of that relationship. The relationships are nearly identical under the socially-optimal, previously-regulated and RTP regimes; the association is weakest under the FP market case, but improves somewhat under DRP.

In the case of a more typical transmission link like line 30 where there is a positive relationship between system load and line flow in all five cases, once again the socially optimal and former regulated regimes yield almost identical results. Here, the relationship is much weaker under the FP market regime, compared to regulation, it becomes almost identical in magnitude but not in statistical significance under DRP, and it is even stronger under RTP, although still not as significant statistically. Thus operators of electrical systems may also find value in the widespread implementation of demand-side participation in market exchanges if it strengthens the predictability of flows on any particular line.

IV. Summing-Up

This series of anecdotes, academic results derived from theoretical, experimental and numerical exercises, and real-world incidents can be combined to formulate a sequence of hypotheses and inferences:

1. If we allow markets to reign in supplying electricity, real-time price can be a very good indicator of the emerging status of system reliability. In particular, there appears to be a nice inverse correlation between price and system frequency which in turn is a good indicator of system stress.
2. Facilitating customer participation, although politically unpopular with respect to what is perceived as an entitlement, confronts many more buyers with the cost-consequences of their behavior - - and indirectly, therefore, their impact on reliability, a public good shared by neighboring customers.
3. Automatic frequency detection devices may offer low-cost, low-hassle ways for many customers to respond to price; thus making customer participation more palatable.
4. In the earlier “Float Together/ Sink Together?” paper [5], the desirability was shown of having portions of large electric systems operate autonomously and of allowing them to separate under duress. That isolation can reduce damage to essential equipment and permit the system to be reassembled far more rapidly than if it crashed everywhere. Widespread customer participation in markets may expand and disperse that “islanding” capability to a local micro-level.
5. Last summer’s Australian experience demonstrates how mandated frequency

- response by large blocks of users can save the electric system from collapse in the face of large disturbances automatically. How much greater would those salutary consequences be were the customers' responses scattered widely over the system?
6. Incidentally, these analyses suggest that the system might be easier to operate, and its overall capacity requirements might be reduced (costs might be lower), were all customers to be actively encouraged to confront the consequences of real-time prices.

V. Conclusions

Just as “distributed generation” (more numerous, widely scattered, but smaller units) is thought to enhance overall system reliability and resilience, so too it is illustrated here how devising methods to have many more customers engaged as active participants in electricity markets (“distributed buyers”) may also enhance their reliability. These conclusions follow regardless of the source of the initial insult on the system: random equipment failure, natural disaster or terrorist assault. In fact an extremely successful coordinated terrorist assault on the power system might be no greater than the random sequence of outages the Australians experienced on August 13, 2004. In that case, decentralized automated demand response, mostly by large blocks of load, effectively muted the consequences of the initial shock and led to the rapid automatic restoration of the system. How much greater might the system's resilience be if many small customers also responded? Note, however, that it is important not to have all of these response mechanisms tied together tightly through a common information delivery system. In that case the electricity system may become more vulnerable through a cyber-attack.

The best way to involve a large number of widely dispersed customers is to simply provide each with a meter capable of detecting electricity system characteristics, like frequency, that are highly correlated with the price they are to pay. Who's to pay for the installation of that metering? Is it in the public interest to have it installed? Perhaps we should take our cue from a substantial infrastructure investment of fifty years ago in “The National Defense Interstate Highway System”. Is what we need today “The Nationwide Anti-Terrorism Electricity Metering Network”? This analysis describes the salutary benefits of getting the customers into the game.

References

- [1] Adilov, N., Light, T., Schuler, R., Schulze, W., Toomey, D., and Zimmerman, R., “Differences in Capacity Requirements, Line Flows and System Operability under Alternative Deregulated Market Structures: Simulations Derived from Experimental Trials”, Proceedings of IEEE Power Engineering Systems 2005 Conference, San Francisco, June 12-16,2005.

- [2] Adilov, N., Light, T., Schuler, R., Schulze, W., Toomey, D., and Zimmerman, R., “Self-Regulating Electricity Markets,” presented at the Advanced Workshop in Regulation and Competition, Rutgers Center for Research in Regulated Industries 17th Annual Western Conference, San Diego, June 24, 2004.
- [3] Faruqui, A. & George, S., “The Value of Dynamic Pricing in Mass Markets”, *The Electricity Journal*, July 2002, pp. 45-55.
- [4] National Electricity Market Management Company Ltd., “ Power System Incident Report – Friday 13 August 2004”, NEMMCO Final Report, Australia, January 28, 2005.
- [5] Schuler, R., “Float Together/ Sink Together? (The Effect of Connectivity on Power Systems”, in Richardson, H., Gordon, P., and Moore, J., *The Economic Impacts of Terrorist Attacks*, Cheltenham, UK: Edward Elgar, 2005 forthcoming.
- [6] Thomas, R., “Markets and Reliability”, Report to Consortium on Electricity Reliability Technology Solutions, Washington, D.C., Jan. 2002.
- [7] Toomey, D., Schulze, W., Schuler, R., Thomas, R., and Thorp, J., “Public Goods and Electric Power: A New Look at the Role of Markets”, Cornell Report to PSERC, Ithaca, NY, August 2005.
- [8] Woo, C-K., Pupp, R., Flaim, T. & Mango, R., “ How Much Do Electric Customers Want to Pay for Reliability? New Evidence on an Old Controversy,” *Energy Systems and Policy*, 15, 1991, pp. 145 - 159.
- [9] Zimmerman, R., Restrepo, C., Dooskin, N., Hartwell, R., Miller, J., Remington, W., Simonoff, J., Lave, L., and Schuler, R., “Electricity Case: Main Report – Risk, Consequences, and Economic Accounting”, CREATE Preliminary Report, NYU, New York, June 6, 2005