

Automated Monitoring and Control Using New Data Integration Paradigm

Mladen Kezunovic, Tanja Djokic
Texas A&M University
U.S.A.

kezunov@ee.tamu.edu, djtanja@tamu.edu

Tatjana Kostic
ABB Switzerland, Corporate Research

tatjana.kostic@ch.abb.com

Abstract

This paper introduces a new paradigm for data integration where the substation field data recorded by monitoring and protection Intelligent Electronic Devices (IEDs) is used to supplement Remote Terminal Unit (RTU) data for Supervisory Control and Data Acquisition (SCADA) system, which improves SCADA and other applications. This data integration paradigm allows very detailed monitoring of the power system and subsequently a more comprehensive decision making opportunities for the control applications. The data interfacing between the substation IEDs and EMS SCADA database to allow for such integration is elaborated on indicating various issues in using present IEC standards 61850 and 61970 to accomplish the required data interfacing. The paper ends with a discussion of the benefits of such an approach.

1. Introduction

Power system control paradigm has changed over the years as the technology for power system monitoring and control has improved. Understanding of the power system complexities has also improved through using better modeling and simulation tools. As a result, we are now capable of defining some new approaches to monitoring and control that were not possible before. This paper will illustrate such an approach that relates to more robust monitoring of the power system topology. The improvement allows for better control decisions during fault clearing sequences when the operators may not be able to derive correct control decisions using the measurements coming from the SCADA system alone. In the late sixties, Thomas DyLiacco and associates introduced a new paradigm for power system real-time control where the four power system states were recognized: Normal, Alert, Emergency, and Restorative [1]. This separation of the states led to the design of many generations of Energy Management Systems (EMS) where the main monitoring part was allocated to the SCADA system. In traditional EMS designs, SCADA RTUs located in the substations did not have an ability to monitor power system transients and other dynamic changes very accurately. Instead, the design

emphasis was on detecting and classifying more common steady state conditions that would allow accurate monitoring in the normal and alert states.

Current state of the art in substation monitoring is quite different. The transitions between power system states can be captured using IEDs, which are digital designs that allow very detailed monitoring, recording and measurements of substation data. This paper focuses on the fact that substation IEDs can be used to significantly enhance the ability of SCADA to capture transient operation involving protective relays [2]. As a result, a new paradigm for data integration and information exchange was introduced as an improved way of performing system monitoring and control [3]. Some advances in data acquisition sensors, sensor networks, signal conditioning, and feature extraction will further enable development of the new data integration and information exchange concept [4]. Also, developments of data interfacing standards and their use for facilitating the data integration and information exchange paradigm were reported [5,6]. The final outcome is an ability of a number of different users of the substation data to get a better view of substation conditions than what is possible with the traditional SCADA systems.

This paper concentrates on a major improvement: a more robust determination of the power system topology. It will be shown how the three types of IEDs, namely Digital Protective Relays (DPRs), Digital Fault Recorders (DFRs) and Circuit Breaker Monitors (CBMs), can be utilized to achieve the proposed benefits [7]. The mentioned benefits can affect decision-making capabilities of system operators, protection engineers, maintenance crews and asset managers [8,9].

The paper first introduces a new requirement for monitoring and control. The concept of being able to track the changes in the power system topology by combining monitoring data related to circuit breaker status obtained from DFRs, CBMs and DPRs is elaborated on next. The implementation issues of integrating field recorded data between IEDs and SCADA is also discussed. The new concept for tracking system topology through interfacing IEDs and SCADA is then discussed. Expected benefits, conclusions acknowledgements, and references are given at the end.

2. New Requirements for Monitoring and Control

At the times when the system topology, determined by the circuit breaker status, is changed by the operation of protective relays, the operators may have difficulty making decisions to restore portions of the system that may have been disconnected by the controllers, unless the operators have a clear way of verifying the system conditions and related topology.

2.1. Present situation

The emergency states in the power system are handled by protective relays, which in the past were of an electromechanical design, and did not have an ability to communicate with RTUs and/or SCADA database. Since the ability to correctly restore power system back to the normal operation heavily depends on an understanding of the power system topology. The need for a robust determination of the topology was recognized very early [10]. This improvement is pretty hard to achieve with the old paradigm where SCADA data is the only source of the topology information, which is known to be not a very reliable source of information when communication errors or grouping of substation contacts are present.

The problem with the SCADA topology information is a lack of redundant measurements that would help improving the robustness of the decision-making by the operators. Besides, the Remote Terminal Units (RTUs) of SCADA are not designed to track the analog measurements very closely. Only the reporting by exception when certain thresholds are exceeded is implemented. During transients, including faults, analog signals change very quickly, and only a closer tracking can give the information about the phase relationships and dynamic changes in the signal magnitudes. As an overall consequence of the limited data measurements available through SCADA, operator decisions are sometimes impaired.

2.2. New requirements

As a result of the technology developments, new requirements for monitoring and control can be set as follows:

Ability to track the system changes very closely

Ability to analyze the events and consequences automatically

Ability to react to system changes quickly

To meet the requirements, the following means can be deployed:

Information extracted from data can be enhanced by additional measurements

The assessments of events can be improved through temporal considerations

The means of obtaining information can be made more powerful through some new data processing techniques

To illustrate the point how the new data integration paradigm can be beneficial, Table 1 indicates how the quality of information may be improved in the case of circuit breaker monitoring. It should be noted that the information quality in this case is obtained by: a.) Getting additional data from different IEDs, b.) Establishing a clear temporal relationship in the data analysis, and c.) Taking advantage of the time-series analysis of historical data.

Table 1. Factors affecting the quality of information

Multiple data sources	Temporal analysis	Historical assessment
CB monitors: control circuit signals, vibration, gas pressure	Sequence of control signal initiations and changes in circuit breaker status	Number of operations and assessment of the opening/closing times
Digital fault recorders: "A" and "B" contacts, phase current changes	Sequence and correlation of changes of the contact status and CB currents	Consistency of "A" and "B" contacts and their reliability
Protective relays: duty cycle currents, $I^2 \cdot t$	Timing of CB operations and current interruptions	Assessment of the duty cycle over long time

To improve the quality of information, the proposed data integration concept allows several techniques to be applied: a.) Use of redundant data, b.) Correlation among different data, and c.) Time-series analysis.

Table 2 illustrates the benefits of such approaches in the case of the circuit breaker monitoring for the purpose of better assessment of the topology.

Table 2. Means of obtaining better CB monitoring information

Data Correlation	Redundant Data	Cumulative impacts
Interpreting CB cause-effect sequences	Multiple IEDs measure CB status and analogs	Counting number of CB operations
Making relationship between status changes and changes in analogs	Confirming CB status based on multiple indications of the status	Taking into account number or repairs and calculating failure rates

3. Tracking the System Topology

A detailed tracking of the system topology is achieved through improved means of monitoring the switching changes and the operating status of a circuit breaker using Digital Protective Relays (DPRs), Digital Fault Recorders (DFRs) and Circuit Breaker Monitors (CBMs).

3.1. New architecture of substation IED connections

Figure 1 illustrates the architecture of legacy connections of substation IEDs with various data processing and information paths as they are utilized today to serve different type of utility staff (protection, maintenance, operations). A modification to the legacy connection, conceptually shown in Figure 2, will have to be introduced to allow for implementation of the new data integration and information exchange paradigm.

3.2. Data integration and processing

Further details of the IED connections are shown in Figure 3. The connections are very typical and are implemented through slightly different wiring practices across the utilities, but the signals obtained by the IEDs involved in the connections are quite similar. To better understand the reasons for wanting to integrate the data, the following points need to be discussed:

- Multiple measurements of the same signals
- Comprehensive coverage of CB status
- Functional relevance of recorded data

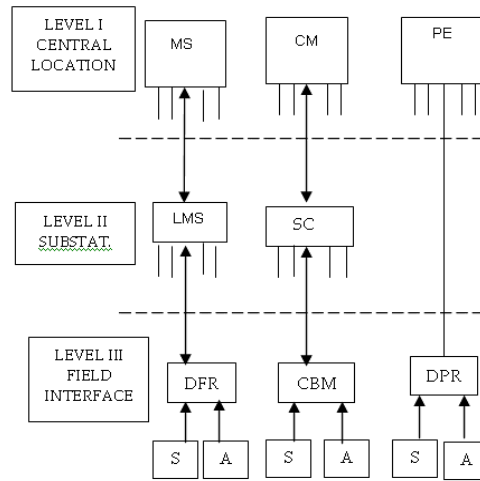

S - Status; A - Analog; MS - Master Station; LMS - Local Master Station; PE - Protection Engineer; CM - Central Maintenance; SC - Substation Concentrator

Figure 1. Legacy connections of DPRs, DFRs and CBMs

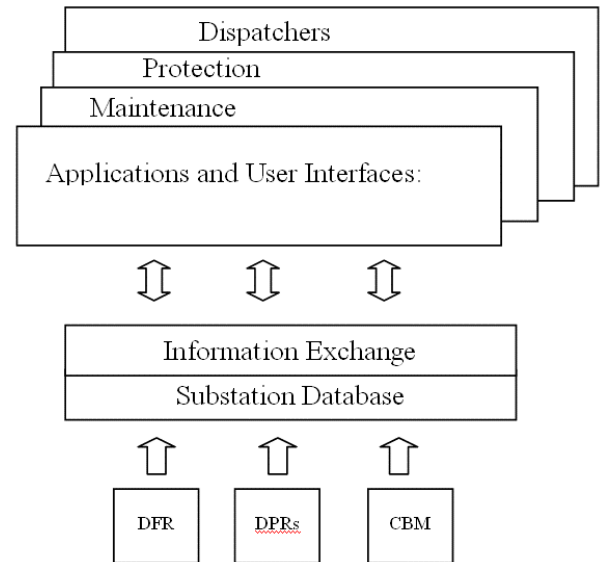

Figure 2. Integration of data from DPRs, DFRs and CBMs

Multiple measurements of the same signals. Table 3 clearly indicates that the three IEDs mentioned in this example do measure several signals that are the same. For example, all three IEDs measure phase currents, “A” and “B” contacts and relay trip signal. This creates redundancy in the measurements that is always desirable since it can be used to verify accuracy of the measurements. Many different signal processing and logic schemes in data processing may be employed to explore the benefits of redundancy.

Comprehensive coverage of CB status. While each of the mentioned IEDs records some of the same signals as the others, each of the IEDs also records some unique additional signals. The examples are the internal control signals recorded by CBM, transient behavior of phase current under variety of switching and fault clearing events recorded by DFR, and additional internal protective relay logic signals associated with the autoreclosing and breaker failure actions of the breaker covered by DPR. The additional signals provide different “view” of the circuit breaker status, and combined provide much more information about the CB status than if they were looked at individually.

Functional relevance of recorded data. While often neglected, it is very important to associate the recorded signals with the specific action that the breaker was engaged in. The reason is rather simple: a correlation between the function and recorded data can provide additional clues about the breaker status. This comes from the fact that manual and /or automatic control actions on the breaker are accompanied with some additional signals from the associated operators and/or controllers, so monitoring the sequence of such signals gives expected final open/close positions of the breaker, and hence allow one to anticipate what should be the expected status.

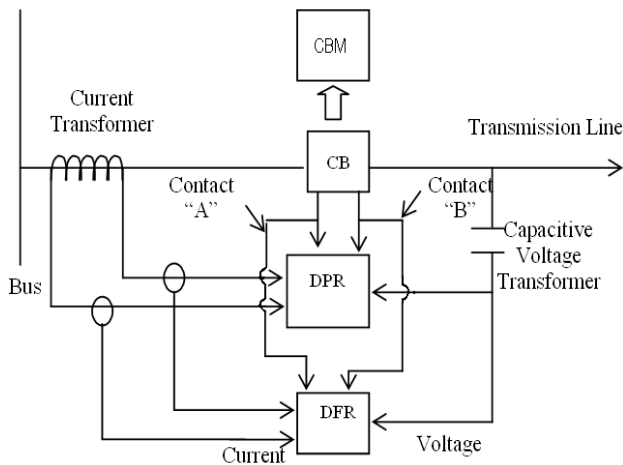

Figure 3. Signal connections for CB monitoring

Table 3. Description of the types of signals for DFRs, DPRs, and CBMs

Digital Fault Recorder	Digital Protective Relay	Circ. Breaker Monitor
“A” and “B” contacts	“A” and “B” contacts	“A” and “B” contacts
Phase currents	Phase currents	Phase currents
Relay trip signal	Relay trip signal	Trip and close initiate
Recloser timing signal	Recloser timing signal	Trip and close currents
Breaker failure initiate	Breaker failure initiate	“X” and “Y” coils
Comm. scheme signals	Comm. scheme signals	DC supply

4. IEC Standards Relevant for Data Integration and Information Exchange

Two emerging standards are related to data interchange in substations (IEC 61850) [5] and control centers (IEC 61970) [6]. Most parts of the former and the most relevant part of the latter have already been adopted as Standards.

Despite the similar application domain (electrical utility control systems) and the foreseeable future integration requirements of Energy Management System (EMS) with Substation Automation System (SAS) applications, the development of the two standards progressed unfortunately quite independently. Only recently has the IEC (the “mother” organization of both standards) through its Technical Committee TC57 specified reference architecture [11] for related standards for electrical utilities, including among them also the two mentioned above.

4.1. Relevant aspects of IEC 61850 and IEC 61970

There are at least three aspects of the specifications in IEC 61850 and IEC 61970 standards relevant to our application:

- (1) The functional qualities, i.e., application data semantics, such as the meaning of circuit breaker and its position;
- (2) The non-functional qualities, i.e., how the application data semantics is modeled. Examples would be a formal modeling language or an informal text description; and,
- (3) The information exchange, i.e., how the actual data instances can be exchanged. This point can further be

subdivided into two, as a function of what information and in what environment it is to be exchanged:

(3.a) The configuration data exchange with help of, e.g., file in a given serialization format. The example would be an XML document describing the circuit breaker with its nameplate data, the information about what primary device it is protecting, and its normal position (open or close); and,

(3.b) The run-time application data exchange through an implementation of, e.g., the application programming interface (API) specified in a given programming language and/or services of the application layer of a given communication stack. The examples for this kind of exchange would be reading the current position of a circuit breaker, or an EMS operator command or protection function trip to change the breaker's position in run-time.

Table 4 summarizes the main characteristics of the two IEC standards relevant to our application.

Table 4 - Comparison of the two IEC standards

	IEC 61850	IEC 61970
Control system domain	SAS	EMS
IT system domain	Substation intra-apps	Control centre intra-apps
Data model	Yes	Yes (CIM)
Serialisation format	Yes (SCL)	Yes (CIMXML)
Communications stack	Yes	No
APIs	No	Yes

4.2. IEC 61850

IEC 61850: Communications Networks and Systems in Substations [5], is a communications standard, with the scope of applications within the substation domain. Its objective is to enable the interoperability of Intelligent Electronic Devices (IED) within the substation. The communications include the so-called substation bus (substation LAN), process bus (bus-oriented link to the I/Os), and peer-to-peer real-time communications between devices. The standard specifies Abstract Communication Service Interfaces (ACSI) and their mappings to concrete communications protocols (e.g., Manufacturing Message Specification, MMS).

In addition, IEC 61850 defines quite an elaborate data model for the substation domain, and a configuration data exchange format as an XML Schema [12][13], called Substation Configuration Language (SCL). The only formally defined (i.e., electronically processable) part of the standard is the SCL, while the domain data and the services to access them are defined in text and

table formats. To circumvent this deficiency, and to be able to model mappings [14] of similar concepts between the IEC 61850 data model and that of IEC 61970, we have developed a formal model [15] using the de facto standard in software engineering, Unified Modeling Language (UML) [16].

The most notable concept with respect to domain data model in IEC 61850 is that of Logical Nodes (LN). LNs model either some atomic protection and control function, typically allocated to an IED (e.g., under-voltage or synchro-check function), or play the proxy for primary equipment (e.g., circuit breaker or measurement transformer). It is the LNs that hold different (standardized) data items, necessary to perform the mentioned atomic function. Data of LNs are, in turn, domain specific abstract data types (ADTs), with several nesting levels. When “unfolded” down to the primitive data types (like integers and booleans), the paths formed with the LN and its data could be seen as standardized “signal names”. For instance, circuit breaker number 3 is modeled by LN of type XCBR. Then, `XCBR3.Pos.stVal` is a read-only data point, which represents the status signal of the position of the breaker; `XCBR3.PosctlVal` is a write-only control signal that allows one to change the position of the breaker; `XCBR3.Pos.sboTimeout` is the configuration parameter related to the select-before-operate mode of breaker control; and `XCBR3.EEHealth.stVal` is the status of the health (condition) of the breaker.

The above example shows that the data contained in LNs is not only that for operation, but also configuration data. Their standardized names (and types), which carry domain semantics, provide a standard way for describing and addressing data of an IED, irrespective of the functions' implementation internal to the IED. This enables interoperability of devices among different vendors, as soon as they provide the IEC 61850 view of their data and the ACSI services implementation for exchange of that data.

4.3. IEC 61970

IEC 61970: Energy Management System Application Programming Interface (EMS-API) [6], normalizes a set of APIs for the manipulation of real-time critical, near real-time and historical EMS/SCADA data. The objective is to support the integration of independently developed applications between vendor specific EMS systems, or between an EMS system and other systems that are concerned with different aspects of power system operations, such as generation or distribution management. In contrast to IEC 61850, this specification does not impose any particular communication stack, but provides only the APIs in

standard IDL. These APIs need to be implemented in a programming language of choice (e.g., Java, C#, CORBA), and run within an execution environment (such as J2EE or .NET) or invoked through Remote Procedure Call, Web Service or other messaging mechanism. Nowadays, the typical communication in these environments would be TCP/IP-based.

Similar to IEC 61850, this specification also defines quite an elaborate data model, Common Information Model (CIM), and a configuration data exchange format. In contrast to the data model of IEC 61850, CIM is already defined in UML, and maintained as a Rational Rose™ model file, which can be browsed online at <http://www.cimuser.com>. The UML model itself and a part of its automatically generated documentation are normative standard documents [6]. The model is also used to automatically derive the CIMXML, serialization format (which is to some extent the counterpart of SCL of IEC 61850). CIMXML is an application of Resource Description Format (RDF) standard [17] to CIM model. More about the usage of CIMXML can be found in [18]. CIM specifies the structure and common semantics for data items that represent power system resources (e.g., a substation, a switch, or a transformer), their attributes (e.g., ampere rating for a breaker), and relationships (e.g., a transformer has two or more windings). It also defines some abstract concepts, such as *Measurement* and *Control*, which are a generic mechanism to model status and control data points (or signals), respectively. The definition of all the domain concepts is in an object-oriented way. This means that the responsibilities in the sense of “what I know of” (i.e., attributes) and “whom I know of” (i.e., associations or relationships with other types) are well spread around the types. Consequently, CIM model has many types and relationships. In turn, each type has relatively few attributes.

For instance, the CIM *Measurement* has relationships to *MeasurementType* and *MeasurementValue*. A number of *Measurements* can be attached to *Terminal* of conducting equipment, such as *Breaker*. The appropriate “path” through relationships of *Measurement* provides for definition of data points (or signals). Thus, the current position of the breaker number 3 would be defined with two data items: `Breaker3.Terminal.Measurement`.

`MeasurementType.name` and `Breaker3.Terminal.Measurement.MeasurementValue.value`, while the breaker’s ampere rating (as configuration parameter) would be defined in `Breaker3.ampRating`. The “short path” names typically means that it is an attribute (as is the case for the latter), and not the relationship to another types.

The above example shows again that the common domain semantics standardizes data exchange, irrespective of internal EMS/SCADA implementation models. It enables integration with EMS systems of different vendors, as soon as they provide the CIM view of their data and the IEC 61970 APIs implementation for exchange of that data.

5. Implementation of Substation Data Integration

According to the IEC 61850 [5], the substation configuration may be modeled using SCL – Substation Configuration Language to form a file, which contains description of substation primary equipment, information about substation IEDs and data that is provided by each device, and how those devices are connected. Using data provided by different IEDs and analyzing substation configuration description (SCD) file that contains information about connection of primary equipment and IEDs as well as description of data provided by those IEDs, Substation Automation System (SAS) application can form substation database.

5.1. Modeling of substation configuration

In order to form substation configuration file, devices functions and data are modeled using appropriate logical nodes classes defined in [5], contained in logical devices that form IEDs.

For instance, circuit breaker with its control circuitry that provides data monitored by CBM can be modeled using XCBR logical node and logical node of type GGIO, contained in a logical device called *Circuit_Breaker_Control* (Figure 4).

Circuit Breaker Monitor (CBM) records signals from circuit breaker control circuitry and provides COMTRADE file as output. It has 15 input channels - 11 analog data channels for recording control voltage, yard voltage, trip current, close current, “A” contact, “B” contact, 3 phase currents and light wire, and 4 status channels for recording trip, close, X coil, Y coil [19].

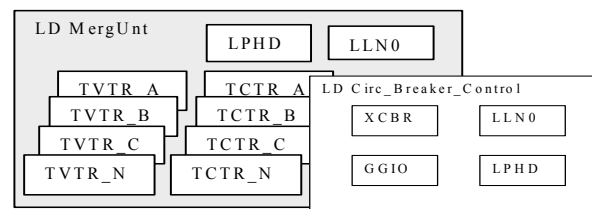

Figure 4. Logical device Merging Unit and Circuit_Breaker_Control

CBM can be modeled using 11 instances of RADR logical node (LN) class for modeling of analog input

channels and additional 4 instances of RBDR LN Class for modeling of 4 digital input signals.

Sampled current values recorded by CBM are provided by instrument current transformers. Instrument current and voltage transformers can be modeled using logical nodes TVTR and TCTR, one per phase and neutral, contained in a logical device Merging Unit that receives current and voltage values from instrument transformers (Figure 4.).

Data provided by logical nodes specify settings, status information, measured values, controlled values. Some data are mandatory and defined in each logical node class (Mod, Beh, Health, NamPlt). Other data are specific for each logical node class and contain information characteristic for the node function. For instance `RADR3.ChNum.setVal` provides information on channel number that is being monitored, `RADR3.ChTrg.stVal` provides information if analogue channel number 3 has started recording. `RDRE.RcdMade.stVal` provides information that disturbance recording has been completed.

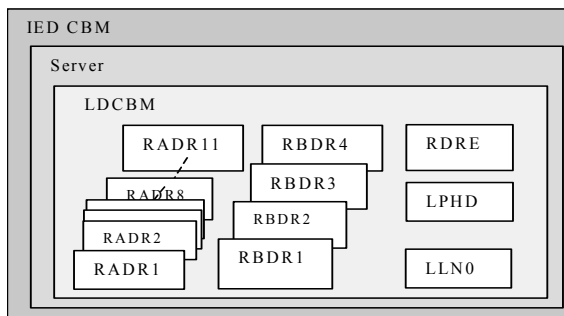

Figure 5. Possible break up of CBM relay to logical devices and logical nodes.

DFR can be modeled in similar way as CBM. Modeling of line distance protection relay with 4 zones, can be done using PDIS logical node class, one instance per zone, PSCH for modeling logic scheme for line protection function coordination, PTRC for trip signal conditioning (Figure 6.). Input signals for distance protection relay are obtained from logical device Merging Unit.

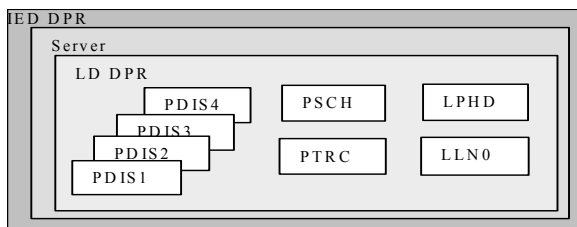

Figure 6. Distance protection relay model

In order to determine status of circuit breaker analyzing redundant data, SAS application has to acquire and analyze data available from CBM and DFR, and status information from circuit breaker itself.

Besides the description of data provided by each IED, substation configuration description file contains information on device connections to substation LAN, reports and log files available from each device and its communication services. Database containing synchronized, redundant data from all protection and monitoring devices in substation can be utilized for more robust determination of substation topology. According to the information contained in SCD file and data received from all substation IEDs, SAS application can form a centralized substation database in a substation.

6. Interfacing Substation and SCADA Topology Data Models

The most notable contribution of the both mentioned standards are their domain models, which define the data semantics for information exchange among the software applications within utility's systems, both back-office and operational ones.

In the context of this work, and with respect to topology-related data exchange between a control centre and the substations, we could identify three scenarios. The typical (simplified) communications architecture is shown in Figure 7, and will be used to describe the topology data exchange scenarios.

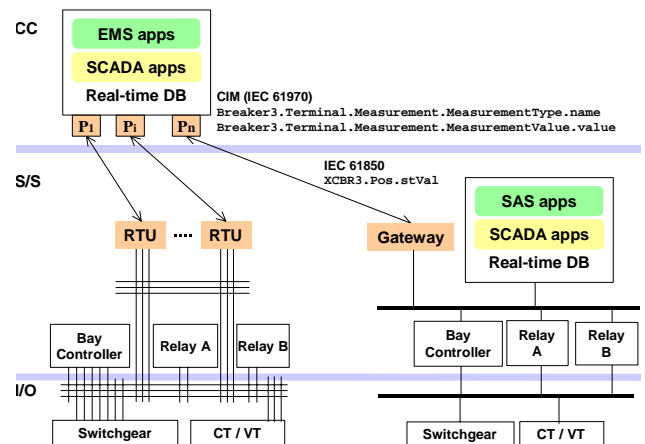

Figure 7. Communications between control centre and substation

Figure 7 shows three hierarchical levels: control centre, substation and process I/O (primary equipment). Two sample substation architectures are shown in the lower part of the figure: on the left side, nowadays predominant architecture with hard-wired process I/Os as well as protection and control devices into RTUs, and on the right side, a full-fledged SAS, with bus-oriented communications over the substation LAN. Bus-oriented communication over substation LAN has several

advantages over architecture with hard-wired process I/Os for the following reasons:

it is cheaper, because there are less wires;

it is less error-prone at commissioning (installation), because there are less wires;

it is more extensible, as new devices can be plugged in with a network card (again, because there are less wires);

less wires require less physical space; etc.

Data exchange between the control centre and the substation relies on one or more so-called RTU protocols (e.g., IEC 60870-101/104, DNP3.0, etc.). The protocol conversion is schematically shown in Figure 7 with boxes P₁, P₂ and P_n on the control centre system side, which typically has to support several RTU protocols. The gateways of modern SAS “play” the RTU, by converting the substation LAN protocol to an RTU one, as expected by control centre.

Finally, Figure 7 shows the example data mappings for the breaker, introduced in the previous sections.

6.1. Configuration mapping (data engineering or signal engineering)

At systems configuration time, either the CIMXML description of a particular substation can be transformed into SCL and used in the SAS, or vice versa, the SCL description of the substation can be converted into a partial CIMXML model and used in the control centre for configuration purposes. For a semi-automatic converter prototype, see [14]. Hypothesis is, of course, that the substation system understands the IEC 61850 data model, and that the control centre system understands CIM.

The data relevant for configuration is of two kinds:

(a) The data describing the functional structure of the substation and its connectivity is described in a serialization format (SCL or CIMXML instance file). This is typical data needed for a single-line diagram, describing the layout of the primary equipment (breakers, switches, lines, busbars, power transformers) and how they are connected. This includes the place of measurement transformers (in SCL), translated into `Measurement` concept of CIM. The mapping between the CIM and the IEC 61850 data model is at the level of types of equipment (i.e., breaker - circuit breaker, line - line, measurement - measurement transformer, etc.); and,

(b) The mappings of concepts representing data points or signals in the two models. This kind of information should rely on a standardized mapping, and applies to any instance of control centre and substation. Examples for this type of mapping have been given earlier for a breaker and its position. Given the standardized mappings, it would be easy to configure

communications links between the SCADA’s process control unit and the substation gateway or RTUs (e.g., by automatically generating the pairs of addresses).

Given the standardized mappings between control centre and substation data models, even if control centre system does not fully implement CIM APIs and the substation system does not fully implement IEC 61850 services, the configuration process of one system can be highly automated from the description given by the other system.

6.2. Run-time: full integration

This scenario implies that the communications front-ends at both sides (control centre and substation) run on the same protocol – either the one specified by IEC 61850 (MMS stack that implements ACSI services) or some higher-level standard messaging mechanism such as CORBA (over IIOP) or Web Services (over HTTP/TCP/IP), which is a free choice according to IEC 61970. It is less likely to have this latter case, due to the performance requirements of run-time data exchange between the substation and the control centre, and the limitations in the link bandwidth. Therefore, the most plausible case is the former, and the pre-conditions for this scenario are as follows:

Both systems’ communication front-ends “understand” their respective data models and have been configured as described in 6.1. above.

At least the gateway of the substation system or the RTUs (see Figure 7) run on IEC 61850, i.e., they provide the concrete implementation of ACSI services (e.g., on MMS stack). Note that in an ideal case, the substation LAN would be IEC 61850, but this is not requirement here.

The process communication unit in the control centre implements IEC 61850 as one of its protocols (e.g., P_n in Figure 7). In the case where the substation LAN is IEC 61850, the gateway would be superfluous from the perspective of the control centre.

In this use-case, substation system does not need to know anything about CIM, but the control centre system must know how to transform the IEC 61850 data model into CIM. The substation is the IEC 61850 server, and the control centre is the IEC 61850 client. Therefore, the process communication unit at control centre has to implement the minimum set of ACSI services, as specified for the client compliance to IEC 61850.

There are in general two possible approaches for control centre to receive topology data at run-time: (a) request-reply mode, i.e., to poll all the status values of positions of switching equipment in the substation at regular time intervals, and (b) publish-subscribe mode, i.e., to subscribe to receive only those values of positions that changed, as soon as they changed. Several ACSI services of IEC 61850 support both request-reply and

publish-subscribe mode of querying data values, and control centre needs to implement, as client, only those that it intends to use.

6.3. Run-time: Integration through file exchange

This case is an intermediate solution, which can be used as a first step towards the full run-time integration described in 6.2 above. The substation system periodically generates a partial CIMXML model, which contains the status values of positions of switching equipment. The values contained could be either all of them at the time of creation of the partial CIMXML file, or only those that have changed since the last creation of the partial CIMXML file. This decision is to be taken at systems configuration time.

The pre-conditions for this scenario are as follows:

Both systems' communication front-ends "understand" their respective data models and have been configured as described in 6.1. above; and,

Both systems' communication front-ends support some kind of file exchange (e.g., over FTP); and,

Operating conditions are normal (secure state).

This scenario would be sufficient to refresh real-time database of the control centre system for state estimation and topology processing applications, which are, under normal operating conditions, run typically every 5 to 60 minutes (this depends on the utility's policy and the control centre SCADA capabilities). In abnormal operating conditions, there might be much more status changes, at high rates, which are not permanent, and thus should not be propagated to the control centre - only the final status should. The usefulness of this scenario is mainly as the first step towards the migration to full run-time integration. Note, also, that for this scenario, it is not necessary to have either side implement any particular protocol (except for file exchange), which means that the existing run-time systems would only need to be interfaced locally to get their respective data, and an independent conversion tool could perform the rest.

7. Expected Benefits of the New Concept

The improved way of monitoring circuit breaker status has one main benefit: more robust topology determination.

The more robust approach comes from:

Having redundant information about the status

Measuring multiple signals related to circuit breaker operation and status

Being able to check the status through functional assessment

Redundant information. As discussed earlier, several measurements taken by different IEDs are related to the same signals. Having the same signals one can perform a comparison and decide if the signals match. In the case they do match, the level of confidence that the measurements are accurate is pretty high. If they do not match, a 2-out-of-3 voting logic may be implemented to select a more reliable outcome.

Multiple measurements. Each of the mentioned IEDs will measure a set of signals that describe a specific operating property of the circuit breaker. Digital relay will monitor changes in the "A" and "B" contacts as well as the level of fault currents interrupted by the breaker. Digital fault recorder will also monitor changes in the "A" and "B" contacts, but will record a sequence of operation of a number of breakers in a given substation as well as the corresponding voltages and currents. Circuit breaker monitor will measure the control circuit signals giving an indication if the electromechanical assembly has performed the closing or opening correctly. The combined measurements give much better information about the breaker status than what is available by each individual set of measurements collected by one IED. The combined measurements have superior information content to what is extracted from the circuit breaker status data collected by RTUs.

Functional assessment. The mentioned IEDs enable monitoring of the functional tasks of the circuit breaker: clearing the faults and changing the topology of the power system. In either case, an automatic controller or an operator initiating the circuit breaker operation, the final outcome of a breaker changing its state or remaining in the same one depends on the function that the breaker was supposed to support. For example, if there is a fault on the transmission line, the voltage and current signals should change (which is recorded by a DFR), the relay should determine the fault location and fault type leading to a decision to trip (or not to trip), and if there is a trip or close command issues, the circuit breaker control circuit monitor records the behavior of the control circuitry. The whole sequence can tell us if the breaker is operating correctly, and if not, what are the possible reasons.

8. Conclusions

Based on the discussions given in the paper, the following conclusions may be reached:

Determining power system topology very accurately using SCADA information only is not always possible

Utilizing data from different IEDs that are connected to a given breaker improves robustness in determining the topology

Integrating such an application with the existing SCADA system is not trivial

Utilizing new IEC standards for integration is a prudent approach, but may require further adjustments to accommodate new applications.

9. Acknowledgments

The authors gratefully acknowledge financial support from the ABB Corporate Research Centre in Switzerland allowing the developments reported in this paper.

10. References

- [1] T. E. Dy Liacco, "Real-time computer control of power systems", Proc. IEEE, vol. 62, no.7, pp.884-891, July 1974
- [2] M Kezunović, "Data Integration and Information Exchange for Enhanced Control and Protection of Power Systems," *Hawaii International Conference on Systems Science*, Waikoloa Village, HI, January 2003.
- [3] M. Kezunovic, and A. Abur, "Data Integration and Information Exchange: Impact on Future Substation and EMS Applications and Related Implementation Requirements", EPRI Technical Report, Project #055434, 2004
- [4] M. Kezunovic, H. Taylor, "New Solutions for Substation Sensing, Signal Processing and Decision Making," Hawaii International Conference on System Sciences HICSS-37, Waikoloa Village, HI, January 2004.
- [5] IEC 61850: Communications Networks and Systems in Substations, International Standard, 2003
- [6] IEC 61970: Energy Management System Application Programming Interface (EMS-API), draft IEC Standard. Part 301: Common Information Model (CIM) Base, v.10.4, May 2003. [Online] Available (model view): <http://www.cimuser.com>
- [7] M. Kezunovic, "Integrating Data and Sharing Information from Various IEDs to Improve Monitoring, Condition-based Diagnostic, Maintenance, Asset Management, and Operation Tasks", in Proc. EPRI Substation Equipment Disturbance Conf., New Orleans, Louisiana, Feb. 2004.
- [8] M. Kezunovic, A. Abur, A. Edris, D. Šobajic, "Data Integration/Exchange Part I: Future Technical and Business Opportunities," IEEE Power & Energy Magazine pp. 14-19, Mar/April 2004.
- [9] M. Kezunovic, A. Abur, A. Edris, D. Šobajic, "Data Integration/Exchange Part II: Future Technical and Business Opportunities," IEEE Power & Energy Magazine pp. 24-29, May/June 2004.
- [10] A. Abur, H. Kim and M. Celik, "Identifying the Unknown Circuit Breaker Statuses in Power Networks", *IEEE Transactions on Power Systems*, Vol.10, No.4, November 1995.
- [11] T. L. Saxton (2002, Nov.). Reference Architecture for TC57. [Online]. Available: ftp://epriapi.kemaconsulting.com/downloads/downloads/IEC_TC57_Reference_Architecture/Ref_Architecture_r5.doc
- [12] W3C, *Extensible Markup Language (XML) 1.0 (Third Edition)*, W3C Recommendation, February 2004. Available: <http://www.w3.org/TR/REC-xml>
- [13] W3C, *XML Schema Part 0: Primer*, W3C Recommendation, May 2001. Available: <http://www.w3.org/TR/xmlschema-0/>
- [14] T. Kostic, O. Preiss, C. Frei, *Towards the Formal Integration of Two Upcoming Standards: IEC 61970 and IEC 61850*, in Proc. of 2003 LESCOPE Conference, pp. 24-29, May 2003.
- [15] T. Kostic and O. Preiss, UML model of IEC 61850 (v6, May 2004) and the data mappings between CIM 10 and IEC 61850. Not published yet (contact authors).
- [16] OMG, *Unified Modelling Language Specification*, Version 1.4, September 2001. [Online]. Available: <http://www.omg.org/uml>
- [17] W3C, *RDF Primer*, <http://www.w3.org/TR/rdf-primer/>, W3C Working Draft, April 2002

- [18] A. deVos, S.E. Widergren, J. Zhu, *XML for CIM Model Exchange*, Proc. IEEE Conference on Power Industry Computer Systems, Sydney, Australia, 2001. Available at <http://www.langdale.com.au/PICA>
- [19] M. Kezunović, G. Latiško, Z. Ren, D. Sevcik, J. Lucey, E. Koch, W. Cook, "Automated Analysis of Circuit Breaker Operation," *17th International Conference on Electricity Distribution – CIRED 2003*, Barcelona, Spain, May 2003.

Biographies



Mladen Kezunovic (S'77–M'80–SM'85–F'99) received the Dipl. Ing. Degree in electrical in 1974, and the M.S. and Ph.D. degrees in electrical engineering from the University of Kansas, Lawrence, in 1977 and 1980, respectively. Currently, he is the Eugene E. Webb Professor and Director of Electric Power and Power Electronics Institute at Texas A&M University, College Station. His main research interests are digital simulators and simulation methods for relay testing as well as application of intelligent methods to power system monitoring, control, and protection. Dr. Kezunovic is also a Fellow of IEEE and a member of CIGRE-Paris.

Tanja Djokic received her B.Sc.degree from the University of Belgrade, Yugoslavia in 1999. She is presently a Research Assistant at Texas A&M University working towards her M.Sc. degree.



Tatjana (Tanja) Kostic (M'95) received her BSEE ('89) and MSEE ('94) from the University of Belgrade, Yugoslavia, and the Dr. of Sc. Techn. degree ('97) from the Swiss Federal Institute of Technology (EPFL), Lausanne, Switzerland. After her post-doc year with

Mitsubishi Electric, Amagasaki, Japan, she joined ABB Corporate Research in Switzerland, where she is currently working as a principal scientist in Utility Solutions group. Her research interests include IT applications for power system operation and for utility asset management, standardized utility domain models, object-oriented analysis and design, and artificial intelligence. She is a member of the IEEE PES and Computer societies, a working member of the Cigré WG C2.01, and an IEC expert in TC57 WG14.